

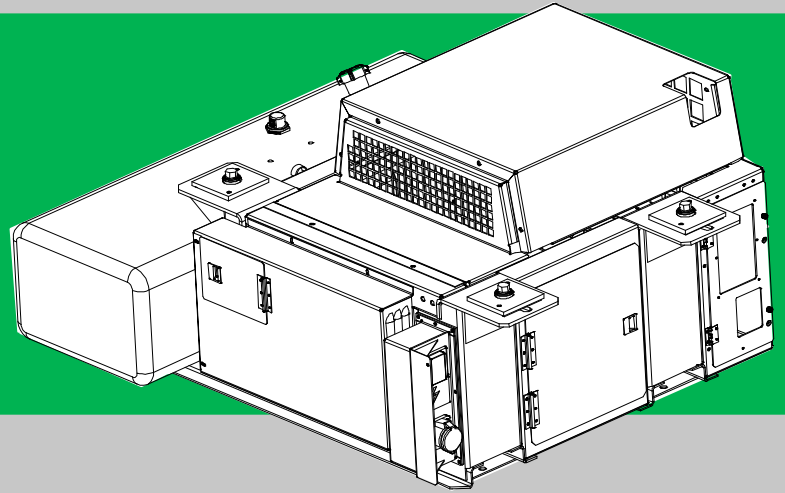

Diesel Generator Set

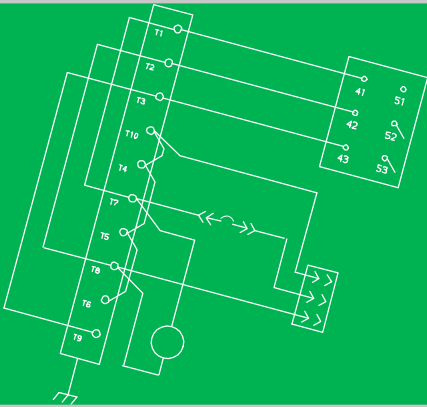

OPERATION AND SERVICE

for

69UG15

Generator Set Units:

PID UG1400 Series

PID UG1500 Series

PID UG1600 Series



TRANSICOLD

**OPERATION AND SERVICE MANUAL
DIESEL DRIVEN GENERATOR SET**

**MODEL
69UG15**

TABLE OF CONTENTS

PARAGRAPH NUMBER	Page
SAFETY SUMMARY	Safety-i
GENERAL SAFETY NOTICES	Safety-i
FIRST AID	Safety-i
OPERATING PRECAUTIONS	Safety-i
MAINTENANCE PRECAUTIONS	Safety-i
UNIT HAZARD LABEL IDENTIFICATION	Safety-i
SPECIFIC WARNING AND CAUTION STATEMENTS	Safety-ii
DESCRIPTION	1-1
1.1 INTRODUCTION	1-1
1.2 CONFIGURATION IDENTIFICATION	1-1
1.3 ENGINE	1-5
1.3.1 Electronic Governor Module	1-5
1.3.2 Engine Air System	1-5
1.3.3 Fuel System	1-5
1.3.4 Lube Oil Filter Arrangement	1-5
1.4 ENGINE SCREW THREADS	1-6
1.5 ALTERNATING CURRENT GENERATOR	1-6
1.5.1 Principle of Operation	1-6
1.5.2 Alternating Current Generator Diagram	1-6
1.6 BATTERY CHARGING SYSTEM	1-6
1.7 OPERATING CONTROLS & INSTRUMENTS	1-7
1.7.1 Introduction	1-7
1.7.2 Control Panel and Related Components	1-7
1.8 SAFETY DEVICES	1-12
1.9 UNIT SPECIFICATIONS	1-13
1.10 ENGINE DATA	1-13
OPERATION	2-1
2.1 GENERATOR SET INSTALLATION	2-1
2.2 GENERATOR SET REMOVAL	2-2
2.3 STARTING AND STOPPING INSTRUCTIONS	2-3
2.3.1 Pre-Start Inspection	2-3
2.3.2 Starting Instructions	2-3
2.3.3 Post-Start Inspection	2-3
2.3.4 Stopping Instructions	2-3
2.4 SEQUENCE OF OPERATION	2-4

TABLE OF CONTENTS – Continued

PARAGRAPH NUMBER	Page
TROUBLESHOOTING	3-1
3.1 DIESEL ENGINE	3-1
3.1.1 Engine Will Not Start	3-1
3.1.2 Engine Starts Then Stops	3-1
3.1.3 Engine Will Not Shut Off	3-2
3.1.4 Starter Motor Malfunction	3-2
3.1.5 Malfunction In The Engine Starting Circuit	3-2
3.1.6 Miscellaneous Engine Troubleshooting	3-3
3.2 BATTERY CHARGER (SOLID STATE)	3-3
3.3 ALTERNATING CURRENT GENERATOR	3-4
3.4 AUTO RE-START OPTION	3-5
3.5 DUAL SPEED OPTION	3-6
3.6 ELECTRONIC GOVERNOR MODULE	3-6
SERVICE AND PREVENTATIVE MAINTENANCE	4-1
4.1 INTRODUCTION	4-1
4.2 PREVENTATIVE MAINTENANCE SCHEDULE	4-1
4.3 BATTERY SERVICE	4-1
4.4 ENGINE SERVICE AND COMPONENTS	4-1
4.4.1 Bleeding the Fuel System	4-1
4.4.2 Servicing Fuel Pump Internal Filter	4-1
4.4.3 Fuel Filter	4-1
4.4.4 In-Line Fuel Strainer (Option)	4-1
4.4.5 Cooling System	4-1
4.4.6 Lube Oil Filter	4-2
4.4.7 Servicing the Low Coolant Sensor (Option)	4-2
4.4.8 Servicing Low Oil Pressure Switch	4-2
4.4.9 Engine Speed	4-2
4.4.10 Replacing the Engine Speed Sensor	4-2
4.4.11 Servicing Poly V-belt	4-3
4.4.12 Engine Air Cleaner	4-3
4.4.13 Engine Crankcase Breather	4-4
4.4.14 Intake Heater Test	4-4
4.4.15 Intake Heater Service	4-4
4.4.16 Intake Heater Switch	4-5
4.5 SERVICING THE ALTERNATING CURRENT GENERATOR	4-5
4.5.1 Preventative Maintenance and Operating Precautions	4-5
4.5.2 Generator Repair/Test Procedures	4-5
4.5.3 Bearing Replacement	4-6
4.5.4 Generator Removal and Installation	4-7
4.6 GENERAL GENERATOR SET MAINTENANCE	4-7
4.6.1 Maintenance Of Painted Surfaces	4-7
4.6.2 Check and Replace Isolators/Shockmounts	4-8
4.7 UNIDRIVE TORQUE REQUIREMENTS	4-9
SCHEMATICS	5-1
5.1 INTRODUCTION	5-1

LIST OF ILLUSTRATIONS

FIGURE NUMBER	Page
Figure 1-1 Generator Set	1-3
Figure 1-2 Generator Set – Top View (Top Frame Members Removed for Clarity)	1-4
Figure 1-3 Electronic Governor Module	1-5
Figure 1-4 Fuel System Diagram	1-5
Figure 1-5 Lube Oil	1-5
Figure 1-6 A-C Generator Circuit Diagram	1-6
Figure 1-7 Standard Control Panel and Box With Dual Speed Option	1-8
Figure 1-8 Customer Specific Control Panel and Box With Dual Speed Option	1-8
Figure 1-9 Auto Restart Control Box and Panel	1-9
Figure 2-1 Generator Set Mounting – Standard Mount	2-1
Figure 2-2 Generator Set Mounting - Quick Mount	2-2
Figure 4-1 Mechanical Fuel Pump	4-1
Figure 4-2 Low Coolant Sensor	4-2
Figure 4-3 Air Cleaner, Dry Element	4-3
Figure 4-4 Air Cleaner, Oil Bath	4-4
Figure 4-5 Engine Crankcase Breather	4-4
Figure 4-6 Intake Heater	4-4
Figure 4-7 A-C Generator Rectifier Assembly	4-6
Figure 4-8 Rectifier Removal	4-6
Figure 4-9 Truss and Isolator	4-7
Figure 4-10 Engine Shockmounts	4-8
Figure 4-11 Generator Shockmounts	4-8
Figure 4-12 Unidrive Torque Requirements	4-9
Figure 5-1 Schematic Diagram - Legend	5-1
Figure 5-2 Schematic Diagram	5-2
Figure 5-3 Schematic Diagram 460 Volt Alternating Current Generator	5-3
Figure 5-4 Schematic Diagram - Legend	5-4
Figure 5-5 Schematic Diagram	5-5
Figure 5-6 Schematic Diagram 460 Volt Alternating Current Generator	5-6
Figure 5-7 Schematic Diagram - Legend	5-7
Figure 5-8 Schematic Diagram	5-8
Figure 5-9 Schematic Diagram 460 Volt Alternating Current Generator	5-9
Figure 5-10 Schematic Diagram - Legend	5-10
Figure 5-11 Schematic Diagram	5-11
Figure 5-12 Schematic Diagram 460 Volt Alternating Current Generator	5-12
Figure 5-13 Schematic Diagram - Legend	5-13
Figure 5-14 Schematic Diagram	5-14
Figure 5-15 Schematic Diagram 460 Volt Alternating Current Generator	5-15

LIST OF TABLES

TABLE NUMBER	Page
Table 1-1 Model Chart	1-2
Table 1-2 Auto Restart Preset Values	1-9
Table 1-3 Auto Restart Sequencing	1-10
Table 1-4 Safety Devices	1-12
Table 4-1 Preventative Maintenance Actions and Schedule	4-10

SAFETY SUMMARY

GENERAL SAFETY NOTICES

The following general safety notices supplement the specific warnings and cautions appearing elsewhere in this manual. They are recommended precautions that must be understood and applied during operation and maintenance of the equipment covered herein. The general safety notices are presented in the following three sections labeled: First Aid, Operating Precautions and Maintenance Precautions. A listing of the specific warnings and cautions appearing elsewhere in the manual follows the general safety notices.

FIRST AID

An injury, no matter how slight, should never go unattended. Always obtain first aid or medical attention immediately.

OPERATING PRECAUTIONS

Always wear safety glasses and hearing protection.

Keep hands, clothing and tools clear of the radiator fan and rotating belts.

No work should be performed on the unit until all circuit breakers and start-stop switches are turned off and the negative battery terminal has been disconnected.

Always work in pairs. Never work on the equipment alone.

In case of severe vibration or unusual noise, stop the unit and investigate.

MAINTENANCE PRECAUTIONS

Be sure power is turned off and the negative battery cable is disconnected before working on generator set.

Do not bypass any electrical safety devices, e.g. bridging an overload, or using any sort of jumper wires. Problems with the system should be diagnosed, and any necessary repairs performed, by qualified service personnel.

In case of electrical fire, open circuit switch and extinguish with CO₂ (never use water).

Fuel Tanks present explosion, fire and rupture hazards even if liquid fuel has been drained. Do not attempt any repairs, especially repairs using flame, welder or torch, unless you have been properly trained and the tank has been emptied of liquid fuel and fuel vapors and the tank is properly ventilated.

UNIT HAZARD LABEL IDENTIFICATION

To help identify the hazard labels on the Unit and explain the level of awareness each one carries, explanations with appropriate consequences are provided below:



Indicates an immediate hazard which WILL result in severe personal injury or death.



Indicates hazards or unsafe conditions which COULD result in severe personal injury or death.



Indicates potential hazards or unsafe practices which COULD result in minor personal injury, product or property damage.

SPECIFIC WARNING AND CAUTION STATEMENTS

The statements that follow are applicable to the generator set and appear elsewhere in this manual. These recommended precautions must be understood and applied during operation and maintenance of the equipment covered herein.

WARNING

Beware of moving poly V-belt, belt driven components and hot exhaust components.

WARNING

Under no circumstances should ether or any other unauthorized starting aids be used in conjunction with the air intake heater.

WARNING

Beware of moving poly V-Belt and belt driven components.

WARNING

Beware of pinch points.

WARNING

Do not use gasoline to clean air cleaner parts.

WARNING

Do not direct water or steam into the generator openings. Do not allow any soap and water solutions to enter the alternator.

WARNING

High voltage (dielectric) testing must not be performed to the machine without first observing NEMA rules. The insulation of this generator winding may be safely checked by using a megger. A high megger reading indicates good insulation.

CAUTION

Observe proper polarity when installing the battery or connecting a battery charger, the negative battery terminal must be grounded. Reverse polarity may damage the charging system. When charging the battery in unit, isolate the battery by disconnecting the negative battery terminal first, then the positive. Once the battery has been charged, connect the positive battery terminal first, then the negative.

CAUTION

Never pour cold water into a hot engine.

CAUTION

Use only ethylene glycol, anti-freeze (with inhibitors) in system. Use of glycol by itself will damage the cooling system.

CAUTION

Never open the radiator cap when the coolant is hot.

CAUTION

Always cover the engine inlet tube while the air cleaner is being serviced.

CAUTION

Do not underfill or overfill the oil bath cups. Overfilling of cups causes loss of capacity; underfilling cups causes lack of filtering efficiency.

CAUTION

When trying to restore residual magnetism, be sure to wear safety glasses and non-conductive gloves. Use an insulated 12 gauge (or higher) jumper wire. Cut off all but a few strands from both ends of the jumper wire to help prevent fusing.

CAUTION

The rotor should not be pulled out from the alternator more than 0.75 inches. Damage to the bearing and windings may result.

CAUTION

Continued operation with failed shockmounts may result in engine or generator damage.

SECTION 1

DESCRIPTION

1.1 INTRODUCTION

The Carrier Transicold model 69UG15 under-mounted diesel-driven generator sets provide electrical power for all-electric refrigeration units.

The generator set (see Figure 1-1 and Figure 1-2) consists of a diesel engine direct-connected to an alternating current generator and mounted in a structural steel frame. The engine is a vertical in-line, four cylinder diesel manufactured by Kubota, while the generator is a 15 kW, brushless, single bearing type manufactured by Lima. The generator provides a constant 460 VAC, three-phase, 60 hertz electrical supply.

Electrical controls are mounted in a control box with operating controls and gauges mounted on a control panel, which also serves as the control box cover. The control panel components are protected by a deflector assembly or a windowed control box door.

Auxiliary engine equipment consists of the battery, solid state battery charging system, "spin-on" lube oil filter, fuel filter and other necessary components for proper unit operation. The water pump and the radiator cooling fan are belt-driven from the engine crankshaft. All references to engine are as viewed from the fly wheel end.

The 69UG15 is available as a standard configuration, with an Auto Restart option or with Auto Restart and Low Coolant Sensor. The Auto Restart option automatically restarts the unit in the event of a unit shutdown. Auto Restart also offers built-in indicators that signal low oil

pressure, high water temperature, overspeed, and other overcrank conditions.

Carrier Transicold's Ecodriven dual speed option provides an energy saving alternative to the practice of continuously running the generator at full speed. This speed reduction results in increased fuel economy, reduced carbon footprint, and lowers operating costs.

1.2 CONFIGURATION IDENTIFICATION

Generator set identification information is provided on a label located below the left mounting pad to the left of the access service door (front facing). The label provides the generator set model number, serial number, and parts identification number (PID). The model number identifies the overall configuration while the PID provides information on specific optional equipment and differences in detailed parts.

Configuration identification for models covered herein are provided in Table 1-1. The model number, serial number and PID number must be included when ordering parts and inquiring about your unit.

Separately bound manuals covering the diesel engine are also available (see the following chart).

Manual/ Form No.	Equipment Covered	Type of Manual
62-11335	V2203-DI	Engine Parts List
62-11362	V2203-DI	Workshop

Table 1-1 Model Chart

Model	PID	Electrical Wiring Schematic and Diagram Figures	Unit Mounting	Receptacle Box	Control Box, 460 Volt
1400 Series, Single Speed					
69UG15-050S-05	UG1450	5-10, 5-11, 5-12	Standard (Figure 2-1)	w/Circuit Breaker	Standard
	UG1451	5-1, 5-2, 5-3	Standard	w/Circuit Breaker	Standard
	UG1452	5-10, 5-11, 5-12	Standard	w/Circuit Breaker	Standard
	UG1453	5-10, 5-11, 5-12	Standard	w/Circuit Breaker	Standard
69UG15-050S-06	UG1455	5-10, 5-11, 5-12	Standard	w/Circuit Breaker	Standard
	UG1456	5-1, 5-2, 5-3	Standard	w/Circuit Breaker	Standard
69UG15-050S-07	UG1457	5-4, 5-5, 5-6	Standard	w/Interlock	Auto-Restart
69UG15-050S-08	UG1458	5-1, 5-2, 5-3	Standard	Customer Specific	Customer Specific
69UG15-050Q-06	UG1459	5-10, 5-11, 5-12	Quick (Figure 2-2)	w/Circuit Breaker	Standard
	UG1460	5-1, 5-2, 5-3	Quick	w/Circuit Breaker	Standard
69UG15-068S-05	UG1461	5-10, 5-11, 5-12	Standard	w/Circuit Breaker	Standard
	UG1462	5-1, 5-2, 5-3	Standard	w/Circuit Breaker	Standard
	UG1463	5-10, 5-11, 5-12	Standard	w/Circuit Breaker	Standard
69UG15-068Q-05	UG1464	5-10, 5-11, 5-12	Quick	w/Circuit Breaker	Standard
69UG15-080S-05	UG1465	5-10, 5-11, 5-12	Standard	w/Circuit Breaker	Standard
69UG15-080Q-05	UG1466	5-10, 5-11, 5-12	Quick	w/Circuit Breaker	Standard
	UG1467	5-1, 5-2, 5-3	Quick	w/Circuit Breaker	Standard
69UG15-068S-06	UG1468	5-7, 5-8, 5-9	Standard	w/Circuit Breaker	Auto-Restart
1500 Series, Dual Speed, W/Fuel Warmer					
69UG15-050S-05	UG1550	5-10, 5-11, 5-12	Standard	w/Circuit Breaker	2-Speed
69UG15-050S-08	UG1558	5-13, 5-14, 5-15	Standard	Customer Specific	Customer Specific
69UG15-068S-05	UG1573	5-10, 5-11, 5-12	Standard	w/Circuit Breaker	2-Speed
69UG15-050S-05	UG1572	5-10, 5-11, 5-12	Standard	w/Circuit Breaker/ Drain	2-Speed
1600 Series, Dual Speed Provision, W/Fuel Heater					
69UG15-050S-05	UG1651	5-10, 5-11, 5-12	Standard	w/Circuit Breaker	2-Speed (prov)
69UG15-050S-08	UG1658	5-10, 5-14, 5-15	Standard	Customer Specific	Customer Specific
69UG15-068S-05	UG1661	5-10, 5-11, 5-12	Standard	w/Circuit Breaker	2-Speed (prov)
69UG15-068Q-05	UG1664	5-10, 5-11, 5-12	Quick	w/Circuit Breaker	2-Speed (prov)
69UG15-050S-05	UG1669	5-10, 5-11, 5-12	Standard	w/Circuit Breaker	2-Speed (prov)
69UG15-068S-05	UG1670	5-10, 5-11, 5-12	Standard	w/Circuit Breaker/ Drain	2-Speed (prov)
69UG15-050S-05	UG1671	5-10, 5-11, 5-12	Standard	w/Circuit Breaker/ Drain	2-Speed (prov)
69UG15-050S-05	UG1672	5-10, 5-11, 5-12	Standard	w/Circuit Breaker/ Drain	2-Speed (prov)

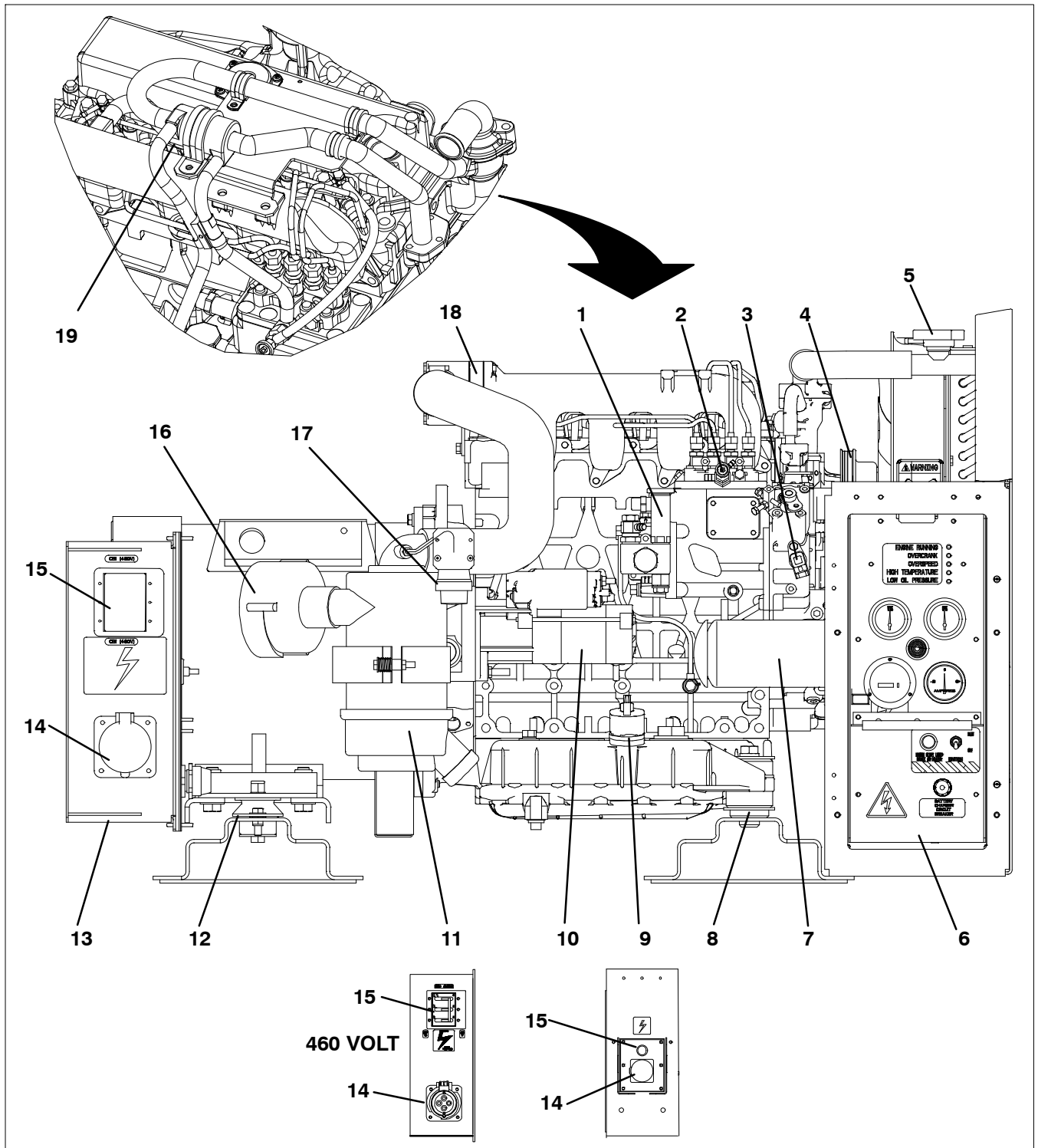

- | | |
|--------------------------------|--|
| 1. Mechanical Fuel Pump | 11. Air Cleaner |
| 2. Injector Pump | 12. Generator Shockmount |
| 3. Engine Speed Sensor | 13. Receptacle Box |
| 4. Poly V-Belt | 14. Receptacle |
| 5. Radiator | 15. Circuit Breaker |
| 6. Controls (See Figure 1-9) | 16. Air Filter Indicator (if equipped) |
| 7. Engine Oil Filter | 17. Air Filter Pre-Cleaner (if equipped) |
| 8. Engine Shockmount (Typical) | 18. Intake Heater (IH) |
| 9. Lube Oil Dipstick/Fill Cap | 19. Fuel Warmer (if equipped) |
| 10. Starter | |

Figure 1-1 Generator Set

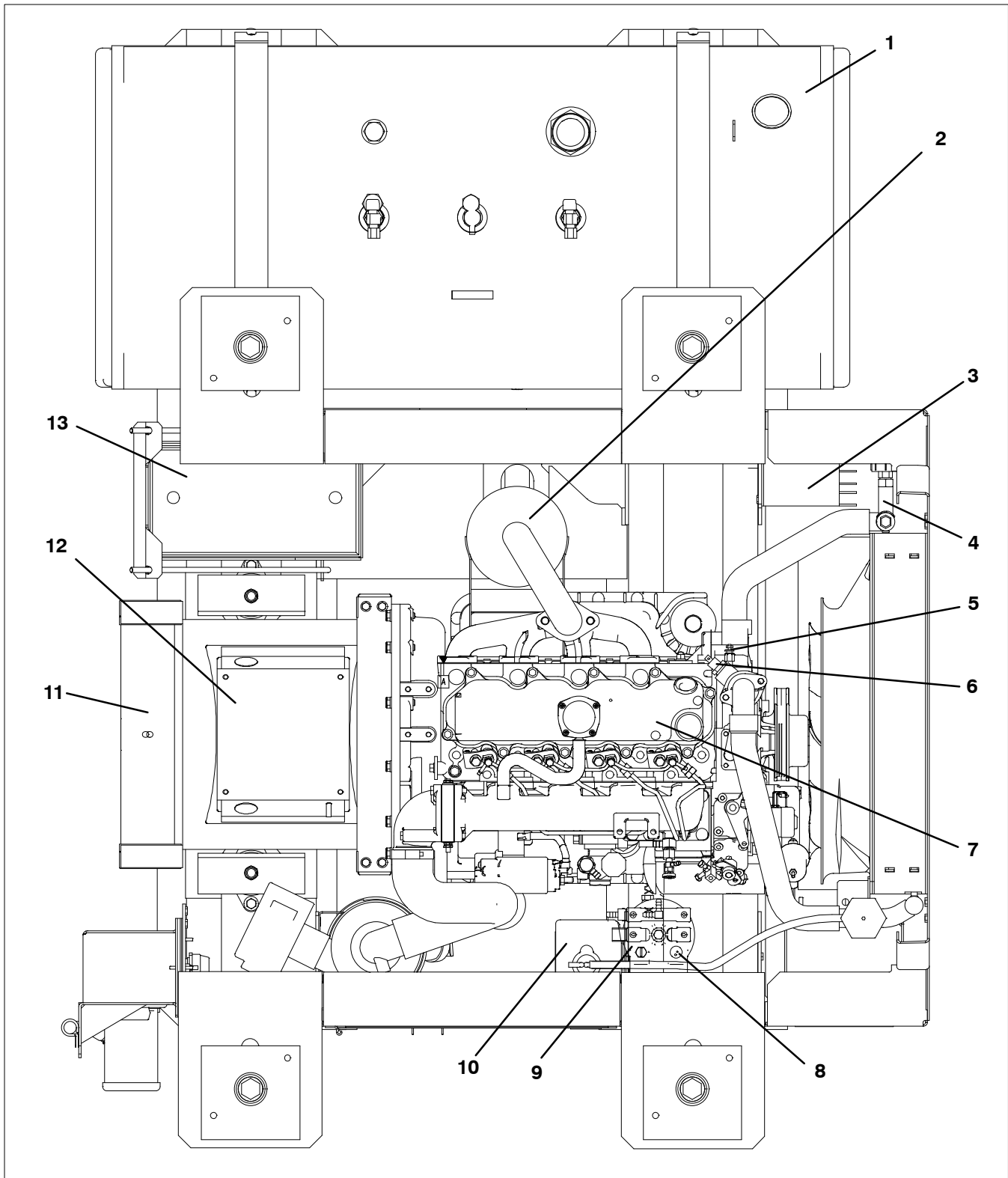

- | | |
|-------------------------------------|--|
| 1. Fuel Tank | 8. Fuel Heater (If Equipped) |
| 2. Exhaust Muffler | 9. Fuel Filter |
| 3. Solid State Battery Charger | 10. Coolant Overflow Bottle |
| 4. Low Coolant Sensor (If Equipped) | 11. Alternating Current Generator |
| 5. Water Temperature Sensor | 12. AC Generator Connection Box Access |
| 6. Water Temperature Switch | 13. Battery |
| 7. Engine | |

Figure 1-2 Generator Set – Top View (Top Frame Members Removed for Clarity)

1.3 ENGINE

The engine is a vertical, in-line four cylinder diesel engine, which is direct-connected to the alternating current generator. Information on the major engine systems is provided in the following subparagraphs.

1.3.1 Electronic Governor Module

The electronic governor module (EG) is a solid state control module preprogrammed for 1800 RPM high speed and 1500 RPM low speed operation. The electronic governor module, along with the engine speed sensor, replaced the manual governor in order to provide constant and economical engine speed.

The unit has an LED which may be used to diagnose failures within the electronic speed control system, refer to Section 3.6 for additional troubleshooting information on diagnosing failures.

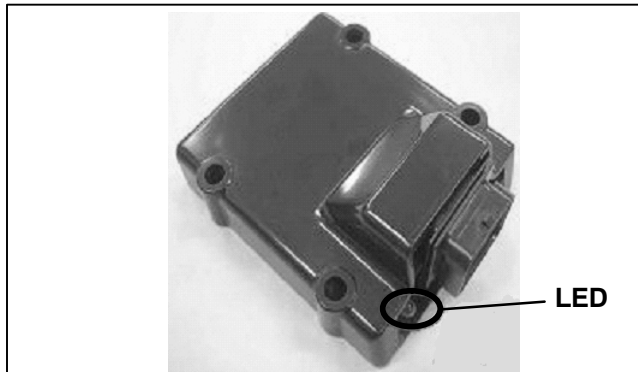

Figure 1-3 Electronic Governor Module

1.3.2 Engine Air System

The air cleaner (Figure 1-1) is designed to prolong engine life and performance by preventing dirt and grit from entering the engine and causing excessive wear on all operating parts. In order for the air filter to operate properly, the operator must regularly maintain the air cleaner equipment in accordance with the instructions provided within this document.

1.3.3 Fuel System

The fuel system is fitted with an in-line fuel strainer and a fuel filter, which also acts as a water separator. The fuel system is shown in Figure 1-4.

There are two fuel heating / warming options:

The fuel heater system is located in the fuel filter, and uses a 12 volt heater to heat fuel as it passes through the fuel filter, see Figure 1-2.

The fuel warming system is a mechanical system that warms fuel by passing it through a heat exchanger that is warmed with engine coolant, see Figure 1-1.

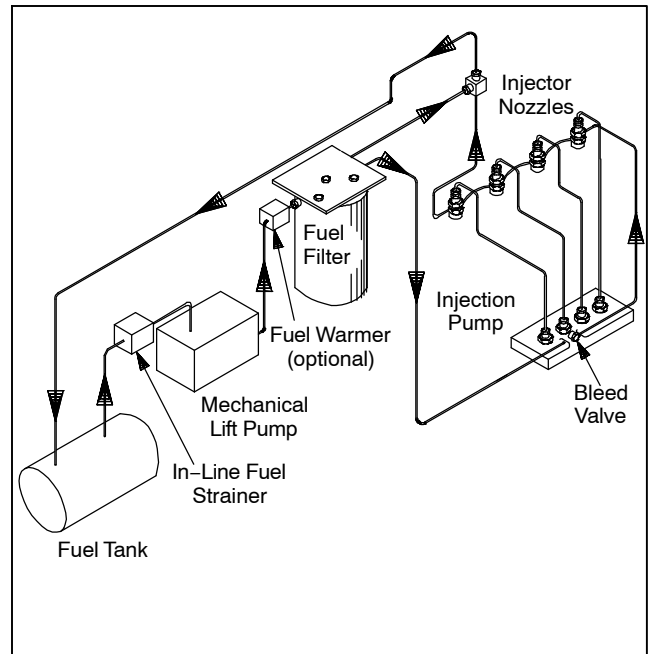
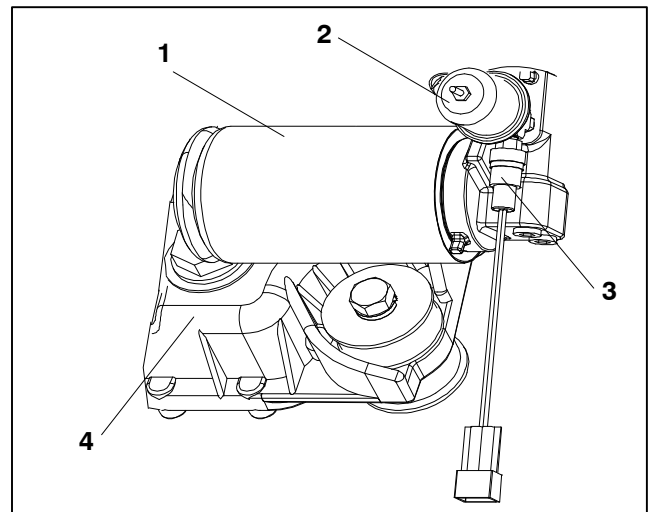

Figure 1-4 Fuel System Diagram

1.3.4 Lube Oil Filter Arrangement

The engine lubricating oil filter is mounted in a horizontal arrangement and shown in Figure 1-5.



1. Oil Filter (Primary)
2. Oil Pressure Sender
3. Oil Pressure Switch
4. Oil Pan

Figure 1-5 Lube Oil

1.4 ENGINE SCREW THREADS

All threads used on the engine are metric except for the oil drain plug, which is American Standard Pipe Thread (NPT).

1.5 ALTERNATING CURRENT GENERATOR

1.5.1 Principle of Operation

The Marathon Alternator Company (Lima) brushless alternating current generator (see Figure 1-2, item 11) is a self-regulated, rotating field synchronous unit. The generator stator and exciter stator are combined in a common housing. The generator field, exciter rotor, and rotating rectifier assembly are mounted on a common shaft. The output of the exciter rotor is applied to the generator field winding through a rotating, full-wave bridge, silicon rectifier unit.

All connections between the exciter stator windings and generator stator windings are internal within the stator housing. Only the output power leads are connected at the terminal box, which is located on top of the generator.

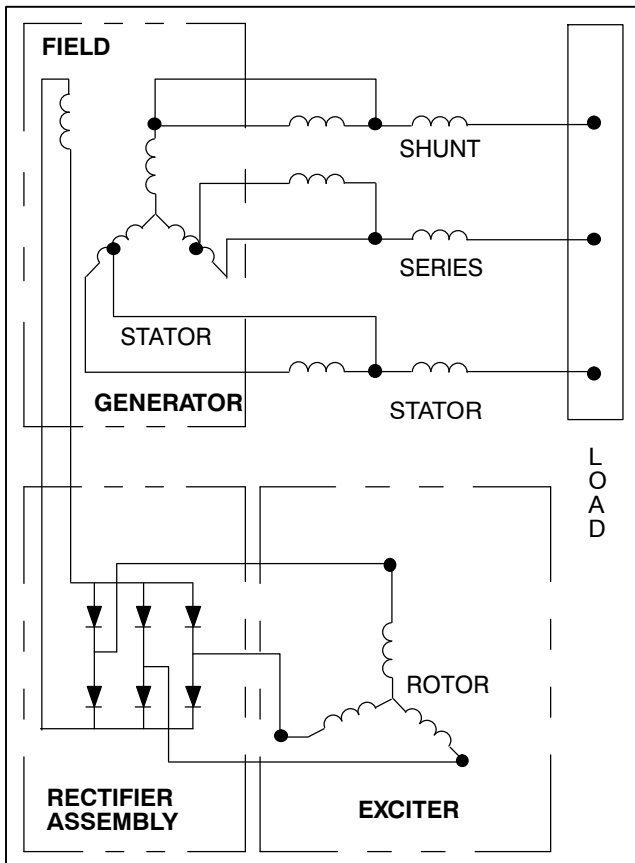

Figure 1-6 A-C Generator Circuit Diagram

1.5.2 Alternating Current Generator Diagram

Figure 1-6 shows the internal schematic diagram of the generator, exciter, and rectifier unit. The generator is a three-phase unit, the exciter stator and exciter rotor also have three-phase windings. A portion of the exciter stator windings is connected across a tap on the generator stator winding. This exciter shunt winding provides the generator field excitation power required for generator no-load voltage. Another portion of exciter stator windings is connected in series with the output of the generator and provides a compounding excitation characteristic.

The rotor is, in effect, the secondary of a rotating current transformer induction frequency converter. The exciter rotor output voltage is applied to the generator field windings by a three-phase, full wave rotating silicon rectifier unit. The response time of the excitation system is very fast as the exciter stator carries an alternating current corresponding to the load current that appears immediately on the exciter primary. An increase in load current will cause an immediate increase in the exciter secondary output voltage, which is rectified and applied to the generator field windings. The inherent compounding characteristics of the excitation system provide excellent voltage regulation even under heavy overload conditions.

1.6 BATTERY CHARGING SYSTEM

The solid state battery charger (see Figure 1-2) is located to the left of the radiator. The charger is powered by the generator, and this input is protected by a circuit breaker located on the control panel. The battery charger produces a tapered charge (25 amps maximum) and is designed not to overcharge the battery.



Observe proper polarity when installing the battery or connecting a battery charger. The negative battery terminal must be grounded. Reverse polarity may damage the charging system. When charging the battery in unit, isolate the battery by disconnecting the negative battery terminal first, then the positive. Once the battery has been charged, connect the positive battery terminal first, then the negative.

1.7 OPERATING CONTROLS & INSTRUMENTS

1.7.1 Introduction

Components required for monitoring and controlling the unit are located in the control box, on the control panel (see Figure 1-1, item 6) and on the receptacle box (see Figure 1-1, item 13).

1.7.2 Control Panel and Related Components

a. Gauges and Senders

1. Oil Pressure Gauge (see Figure 1-7, Figure 1-8, Figure 1-9)

The purpose of this gauge is to observe normal operating engine oil pressure. Normal oil pressure is 35 to 60 psig (3.3 to 5.2 kg/cm²).

2. Oil Pressure Sender (see Figure 1-5)

This device senses engine lube oil pressure and transmits a signal to the oil pressure gauge. The oil pressure sender is located on the oil filter housing.

3. Water Temperature Gauge (see Figure 1-7, Figure 1-8, Figure 1-9)

The function of this gauge is to observe water operating temperature. The gauge is connected to the water temperature sender.

4. Water Temperature Sender (see Figure 1-2)

This device senses engine water temperature and transmits a signal to the water temperature gauge.

5. Low Coolant Sensor (see Figure 1-2)

This device senses the coolant level inside the radiator and will complete a conductive circuit as long as the probes remain immersed in coolant. When the coolant level falls below the probes, a signal will be sent to the auto restart module, shutting down the engine and all 12-volt circuitry.

6. Auto Restart Module

Auto start/restart is provided to simplify the start-up process and provide an automatic restart feature that will automatically attempt to restart the unit in the event of shutdown. Four LEDs are used to indicate shutdown from overcrank, overspeed, low oil pressure, and high water temperature. A fifth LED is used to indicate the unit is running (see Figure 1-9). Refer to Table 1-2 for system preset values.

The auto restart function will perform a series of six attempts to restart the unit and make three attempts within each series. Once the function has completed all 18 attempts, the unit will automatically lock out future crank attempts. Refer to Table 1-3 for detailed information on auto restart sequencing.

b. Meters

1. Ammeter (A)

The ammeter (see Figure 1-7, Figure 1-8, Figure 1-9) is an indicator of the charging system and unit electrical draw. It indicates the rate of discharge or charge of the battery. During start up, the intake heater draws approximately 42 amps.

2. Total Time Meter (TT)

The total time meter (see Figure 1-7, Figure 1-8, Figure 1-9) calculates the total hours and provides an accurate readout of accumulated engine running time. This data can be used to establish the proper periodic maintenance schedule (refer to Section 4.1).

c. Manual Switches

1. Intake Heater Switch (HS) (see Figure 1-7, Figure 1-8)

The intake heater switch is of the momentary type. When held in the PREHEAT position, the switch allows approximately 42 amps of battery current to flow into the intake heater, which preheats the air within the intake manifold and allows the engine to start. After starting the engine, the intake heater switch should continue to be held in the ON position for approximately 5 seconds until the engine has developed enough oil pressure to close the oil pressure safety switch.

2. Ignition Switch (IGN) (see Figure 1-7, Figure 1-8, Figure 1-9)

The ignition switch is of the momentary type to be used in the OFF/ON/START positions. When held in the START (ignition) position, it energizes the starter motor solenoid, which in turn allows the starter motor to crank the engine. The switch is released to the RUN position once the engine has started.

3. Ignition Switch (IGN)(Auto Restart) (see Figure 1-9)

The ignition switch is of the maintained contact type to be used in the RUN/OFF positions. When switched to the RUN position, it energizes the control module, which in turn controls all functions of the genset.

4. Operating Mode Switch (see Figure 1-7, Figure 1-8)

The Operating Mode (Dual Speed) switch is of the maintained contact type to be used in the ECONOMY/POWER positions. When switched to the ECONOMY position, it energizes the dual speed timer control module, which signals the programmed electronic governor module (EG) to reduce engine speed from 1800 RPM to 1500 RPM after a period of two (2) hours.

d. Timers

1. Intake Heater Timer (IHT)

The Intake Heater Timer continues to supply power to the intake heater for 3 minutes after initial start-up.

2. Dual Speed Timer (DT)

The Dual Speed Timer provides power to the electronic governor module for a 2 hour period to maintain initial high speed operation.

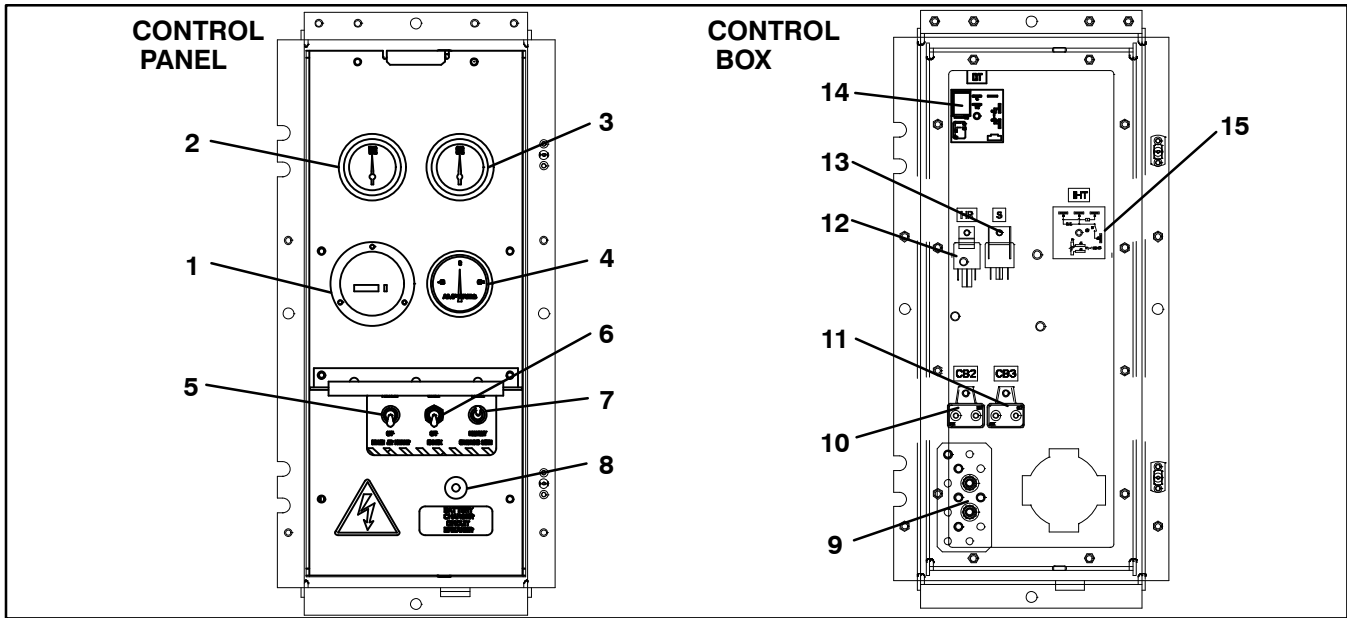

- | | |
|--|------------------------------------|
| 1. Total Time Meter | 9. Ground Studs |
| 2. Water Temperature Gauge | 10. Circuit Breaker (CB2) |
| 3. Oil Pressure Gauge | 11. Circuit Breaker (CB3) |
| 4. Ammeter | 12. Intake Heater Relay |
| 5. Intake Heater Switch | 13. Safety Relay |
| 6. Ignition Switch | 14. Dual Speed Timer (If Equipped) |
| 7. Dual Speed Switch (If Equipped) | 15. Intake Heater Timer |
| 8. Battery Charger Circuit Breaker (CB5) | |

Figure 1-7 Standard Control Panel and Box With Dual Speed Option

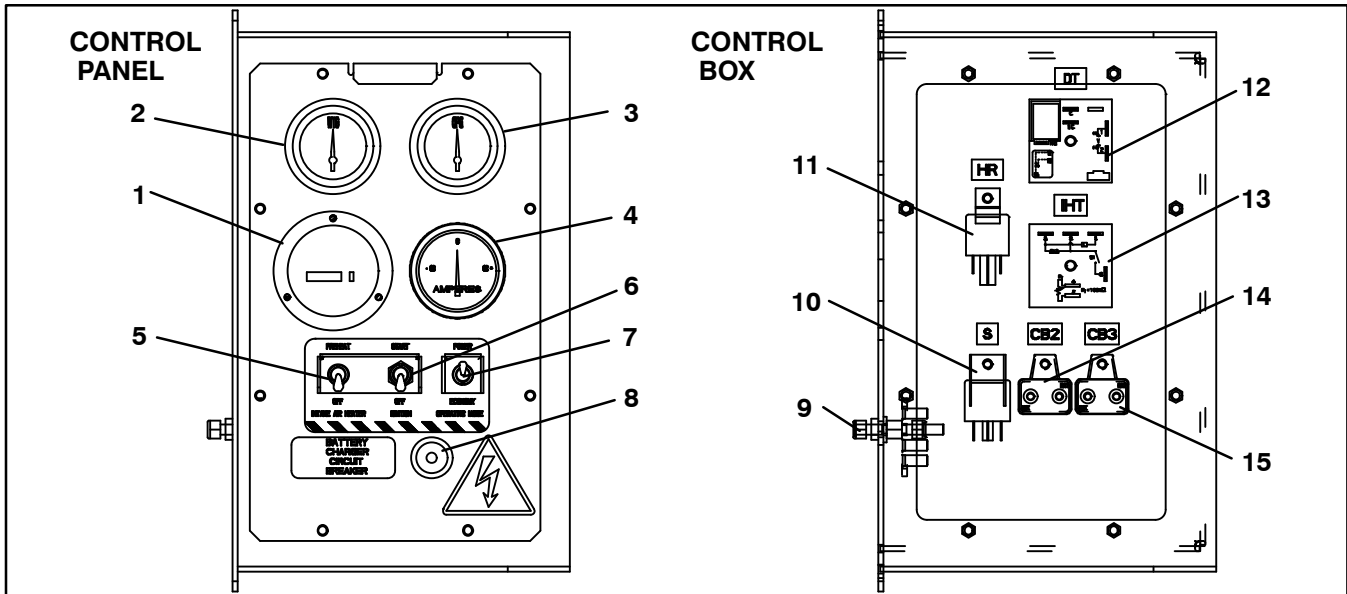

- | | |
|--|------------------------------------|
| 1. Total Time Meter | 9. Ground Studs |
| 2. Water Temperature Gauge | 10. Safety Relay |
| 3. Oil Pressure Gauge | 11. Intake Heater Relay |
| 4. Ammeter | 12. Dual Speed Timer (If Equipped) |
| 5. Intake Heater Switch | 13. Intake Heater Timer |
| 6. Ignition Switch | 14. Circuit Breaker (CB2) |
| 7. Dual Speed Switch (If Equipped) | 15. Circuit Breaker (CB3) |
| 8. Battery Charger Fuse or Circuit Breaker (CB5) | |

Figure 1-8 Customer Specific Control Panel and Box With Dual Speed Option

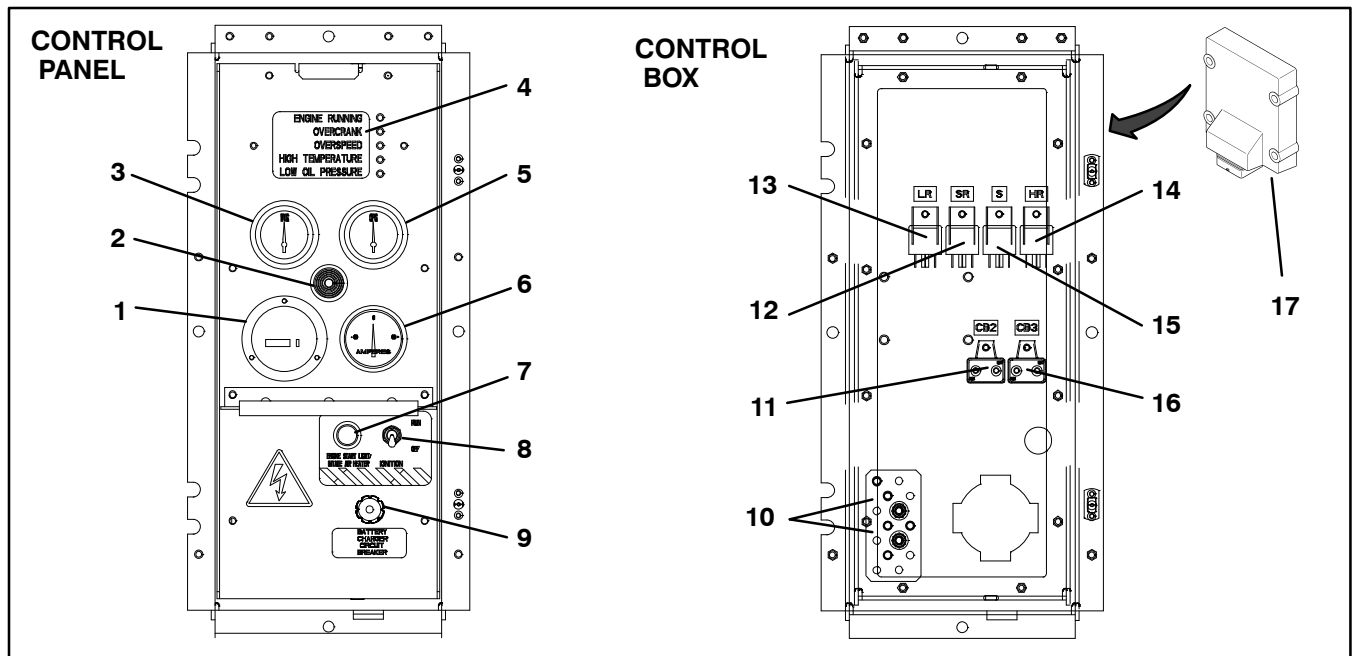

- | | |
|---|--|
| <ul style="list-style-type: none"> 1. Total Time Meter 2. Engine Start Alarm (Buzzer) 3. Water Temperature Gauge 4. Auto Restart Module 5. Oil Pressure Gauge 6. Ammeter 7. Engine Start/Intake Heater Energized Light 8. Ignition Switch | <ul style="list-style-type: none"> 9. Battery Charger Fuse or Circuit Breaker (CB5) 10. Ground Studs 11. Circuit Breaker (CB2) 12. Starter Relay (SR) 13. Low Coolant Relay (LR) 14. Intake Heater Relay (HR) 15. Safety Relay (S) 16. Circuit Breaker (CB3) 17. Speed Control Module |
|---|--|

Figure 1-9 Auto Restart Control Box and Panel

Table 1-2 Auto Restart Preset Values

Indicator	Preset Value	Description
Overspeed	2100 RPM	Overspeed is the point at which the unit will signal for shutdown.
Crank Disconnect	700 RPM	Crank Disconnect is the point at which the auto restart module senses the engine has started and will disengage the starter.
Shutdown Lockout Delay	15 seconds	The oil pressure and water temperature inputs are ignored during this 15 second delay (after start up).
Intake Heater Delay	30 seconds preheat 3 minutes post heat	The delay is used during start up. The intake heater delay begins timing after the auto restart module signal is received. During the entire delay, the intake heater circuit will be energized, an indicator light will be illuminated, and an alarm will sound. When the delay expires, the unit will crank.
Crank Attempts	18 attempts	A series of six attempts with three attempts in each series for a total of 18 attempts, refer to Table 1-3, Auto Restart Sequencing.

Table 1-3 Auto Restart Sequencing

*Engine crank and rest is repeated three times each series unless the engine starts.

Series Attempt Number	Intake Heater Energized in Seconds	Fuel Solenoid Engaged	Engine Crank Duration (Seconds)	Engine Rest Duration (Seconds)	Engine Status
1	30	X	Up To 15	25	<p>If the engine starts:</p> <ul style="list-style-type: none"> a. Run sequence begins b. Intake heater remains energized for 3 minutes <p>If the engine fails to start:</p> <ul style="list-style-type: none"> a. Intake heater will de-energize. b. Fuel solenoid will de-energize. c. Crank output will de-energize. d. Overcrank LED will flash once. Wait two seconds and repeat. e. Unit will rest 30 minutes and proceed to the next series.
2	30	X	Up To 15	25	<p>If the engine starts:</p> <ul style="list-style-type: none"> a. Run sequence begins. b. Intake heater remains energized for 3 minutes. <p>If the engine fails to start:</p> <ul style="list-style-type: none"> a. Intake heater will de-energize. b. Fuel solenoid will de-energize. c. Crank output will de-energize. d. Overcrank LED will flash twice. Wait two seconds and repeat. e. Unit will rest 30 minutes and proceed to the next series.
3	30	X	Up To 15	25	<p>If the engine starts:</p> <ul style="list-style-type: none"> a. Run sequence begins. <p>If the engine fails to start:</p> <ul style="list-style-type: none"> a. Intake heater will de-energize. b. Fuel solenoid will de-energize. c. Crank output will de-energize. d. Overcrank LED will flash three times. Wait two seconds and repeat. e. Unit will rest five hours and proceed to the next series.

Table 1-3 Auto Restart Sequencing (Continued)

Series Attempt Number	Intake Heater Energized in Seconds	Fuel Solenoid Engaged	Engine Crank Duration (Seconds)	Engine Rest Duration (Seconds)	Engine Status
4	30	X	Up To 15	25	<p>If the engine starts:</p> <p>a. Run sequence begins.</p> <p>If the engine fails to start:</p> <p>a. Intake heater will de-energize.</p> <p>b. Fuel solenoid will de-energize.</p> <p>c. Crank output will de-energize.</p> <p>d. Overcrank LED will flash four times. Wait two seconds and repeat.</p> <p>e. Unit will rest five hours and proceed to the next series.</p>
5	30	X	Up To 15	25	<p>If the engine starts:</p> <p>a. Run sequence begins.</p> <p>If the engine fails to start:</p> <p>a. Intake heater will de-energize.</p> <p>b. Fuel solenoid will de-energize.</p> <p>c. Crank output will de-energize.</p> <p>d. Overcrank LED will flash five times. Wait two seconds and repeat.</p> <p>e. Unit will rest five hours and proceed to the next series.</p>
6	30	X	Up To 15	25	<p>If the engine starts:</p> <p>a. Run sequence begins.</p> <p>If the engine fails to start:</p> <p>a. Intake heater will de-energize.</p> <p>b. Fuel solenoid will de-energize.</p> <p>c. Crank output will de-energize.</p> <p>d. Overcrank LED will illuminate solid and lock out future crank attempts.</p> <p>e. To reset, turn unit power switch OFF and back ON.</p>

1.8 SAFETY DEVICES

Safety devices, such as circuit breakers, fuses, and safety switches, protect system components from damage.

The AC generator, solid state battery charger, fuel heater, high water temperature, safety relay, total time meter and intake heater are protected by circuit breakers. If a safety device opens and there is an interruption of electrical current, the electronic governor module will be de-energized, which will also de-energize the fuel solenoid, interrupt the fuel flow to the engine and stop the engine.

In units with auto restart, the engine, engine control devices, and engine monitoring devices are protected by the auto restart module, low coolant sensor (if equipped), circuit breaker, low oil pressure switch, and high water temperature switch. These safety devices monitor system operating conditions and open a set of electrical contacts when an unsafe condition occurs. If a safety device opens and there is an interruption of electrical current, the electronic governor module will be de-energized, which will also de-energize the fuel solenoid, interrupt the fuel flow to the engine and stop the engine.

De-energizing the fuel solenoid shuts off the fuel supply to the engine; thus stopping the engine. Safety device specifications are provided in Table 1-4.

Table 1-4 Safety Devices

Unsafe Condition	Safety Switch	Switch Setting
ENGINE		
Low engine lubricating oil pressure	Low oil pressure switch (LOP) – Automatic reset	Opens below 18 psig (1.27 kg/cm ²)
High engine cooling water temperature	Water temperature switch (HWT) – Automatic reset	Opens at 230°F (110°C)
Low coolant	Low coolant sensor Automatic reset	Opens with a loss of 32 ounces of coolant
Excessive current draw by the safety relay, fuel heater, water temperature gauge, oil pressure gauge or total time meter	Circuit breaker (CB-2) – Automatic reset	Trips at 30 amps
Excessive current draw by the electronic governor module	Fuse 1, 2, 3	Trips at 10 amps
INTAKE HEATER		
Excessive current draw on intake heater circuit	Circuit breaker (CB-3) – Automatic reset	Opens at 50 amps
BATTERY CHARGER		
Excessive current draw on 230 volt feed circuit	Circuit breaker (CB-5) – Manual reset	Opens at 3 amps
GENERATOR		
Excessive current draw by load	Circuit breaker (CB-1, 460 volt) – Manual reset	Trips at 26 amps (460 VAC)

1.9 UNIT SPECIFICATIONS

	Nominal Tank Sizes	Fill Capacity	Draw Capacity
a. Fuel Tanks	50 Gallon Steel	52 gallons (256 liters)	50 gallons* (246 liters)
	50 Gallon Aluminum	52 gallons (256 liters)	50 gallons* (246 liters)
	65 Gallon Steel	67.5 gallons (197 liters)	65 gallons* (189 liters)
	80 Gallon Aluminum	85 gallons (322 liters)	80 gallons* (303 liters)

*Allows for DOT required 5% vapor space

b. Weights	Battery	63 lb (28.6 kg)
	Generator (A-C)	280 lb (127 kg)
	Engine (Dry) – without Accessories	434 lb (197 kg) Approximate
	Unit (with 50 gal steel tank, dry)	1555 lb (705.3 kg)
	Unit (with 50 gal aluminum tank, dry)	1485 lb (673.6 kg)
	Unit (with 65 gal steel tank, dry)	1580 lb (716.7 kg)
	Unit (with 80 gal aluminum tank, dry)	1545 lb (700.8 kg)

1.10 ENGINE DATA

a. Bore/Stroke	3.26 in. (38 mm) / 4.03 in. (102.4 mm)			
b. Compression Ratio	21.5 : 1			
c. Cylinders (Number)	Four			
d. Displacement	135.2 cubic inches (2.22 liters)			
e. Firing Order	1-3-4-2			
f. Lubrication System	Oil Pressure Safety Switch Setting Opens	18 psig (1.27 kg/cm ²)		
	Capacity	Engine – 16.0 US quarts (15.1 liters), includes standard filter.		
	Oil Level Indicator	Dipstick in oil pan or fill cap NOTE To check oil level on engines with the dipstick mounted in the fill cap, remove the cap and wipe the dipstick clean. Insert the cap back onto the oil fill tube, then remove to check level. It is not necessary to screw the cap back into the fill tube when checking level. DO NOT add oil if level is within the “safe” range. If needed, add oil to bring level within the “safe” range. Screw cap fully into fill tube after checking level.		
	Lube Oil Specification	Use a heavy duty lubricating oil conforming to American Petroleum Institute (API) Service Classification CG, CH or CI, Base Number 10 or above.		
	Lube Oil Viscosity	Outdoor Temperature		
		Fahrenheit	Centigrade	SAE
0°F to 45°F		-18°C to 7°C	10W30	
	45°F and above	7°C and above	10W30 or 15W40	
g. Fuel and Fuel Heater Thermostat (FHT)	Winter		Summer	
	Diesel No. 1		Diesel No. 2	
	FHT			
	Close on temperature fall @ 45+/- 6.5°F		Open on temperature rise @ 75+/- 6.5 °F	
	Power Consumption: 150 Watts @ +/- 10% at 14 VDC			
h. Fuel Warmer	Coolant Temperature			

1.10 ENGINE DATA (Continued)

i. Intake Heater	Amperage – 42 amps at 12 VDC		
	Resistance (cold) – Approx. 0.3 ohms		
j. Horsepower	27 HP @ 1800 RPM at 3000 feet above sea level.		
	32 HP @ 1800 RPM at sea level.		
k. Cooling System	Capacity	6 U.S. quarts (5.68 liters) – includes 1 quart (0.95 liter) in coolant recovery bottle. (Refer to section 4.4.5)	
	Anti-Freeze: Conventional	The cooling system may be factory charged with a 50/50 mix of ethylene glycol and water. This mixture provides protection to –34°F (–37°C). For replacement, use a low silicate anti-freeze meeting GM specifications GM 6038M or equal. Again, a 50/50 mix is recommended.	
	Anti-Freeze: Extended Life	The cooling system may be factory charged with a 50/50 mix of extended life coolant (ELC) and deionized water. This mixture provides protection to –34°F (–37°C). For replacement, with extended life coolant (ELC) meeting GM specification GM6277M and deionized water. Again, a 50/50 mix is recommended. Extended life coolant is red or orange in color. DO NOT mix with conventional coolant.	
	Water Temperature Safety Switch Setting	Opens	230 +/- 5°F (110 +/- 3°C)
		Resets	200°F (93°C) – minimum
	Thermostat	Starts to open	177 to 182°F (80 to 84°C)
		Fully open	203°F (95°C)
Low Coolant Sensor	Opens	Loss of 32 ounces of coolant or more Refilling of radiator to proper level	
	Closes		
l. Lubrication System	Oil Pressure	35 to 60 psig (3.3 to 5.2 kg/cm ²)	
m. Electrical	Generator	460 VAC (+/- 10%) @ 60 hz	

SECTION 2

OPERATION

2.1 GENERATOR SET INSTALLATION

The generator set is mounted under the center of the trailer chassis and is easily handled with a fork lift truck capable of handling 2,000 pounds. The fork lift pockets provided are accessible from either side. Mounting clamps are designed to be attached to outside I-beam flanges only. Maximum chassis width is 38 inches on center.

a. Standard Mount

1. Loosen mounting bolts (see Figure 2-1) sufficient to push mounting plates to the outermost position.
2. Place forks into fork lift pockets of generator set. Attach safety chain between unit and fork truck.
3. Center generator under chassis slide mounting plates fully onto chassis I-beams and torque mounting bolts to 80 - 90 ft-lbs (11.1 - 12.4 mkg). Upon completion, remove safety chain before removing forks of fork lift truck from unit.

b. Quick Mount

1. Loosen mounting bolts (see Figure 2-2) sufficient to bring clamp to open position. To orient in open position, lift nut end of bolt out of slot. Clamp will fall open.
2. Place forks into fork lift pockets of generator. Attach safety chain between unit and fork truck.
3. Center the generator set in desired position under chassis.
4. Lift clamp (item 1) in place, ensuring bolt (item 4) is secured in slot.
5. Tighten bolt to 55 - 65 ft-lbs (7.6 - 9.0 mkg).
6. Upon completion, remove safety chain before removing forks of fork lift truck from unit.

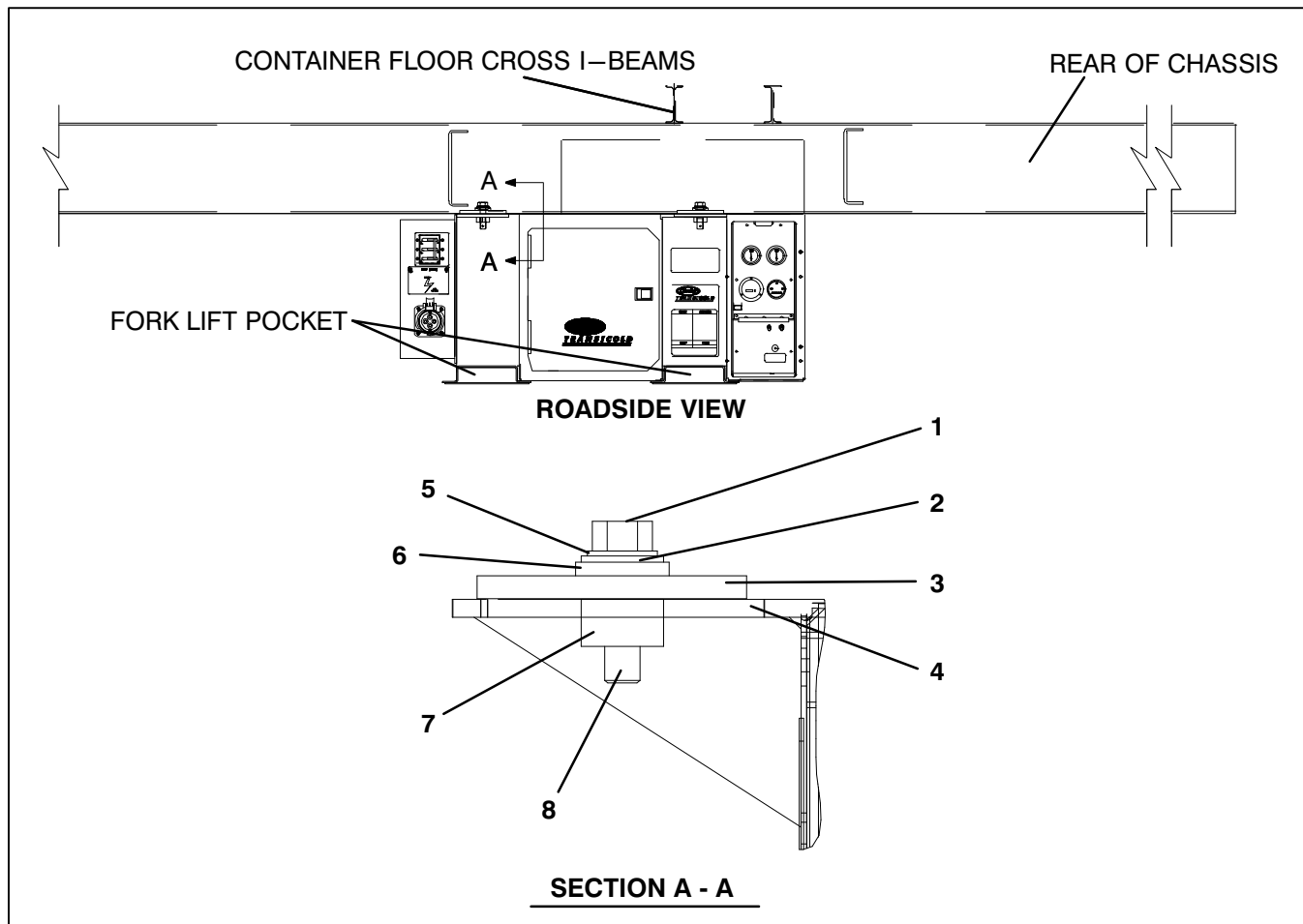

1. Bolt
2. Washer, Spherical, Male
3. Mounting Plate
4. Generator Frame

5. Washer, Belleville
6. Washer, Spherical, Female
7. Tee Nut
8. Roll Pin

Figure 2-1 Generator Set Mounting – Standard Mount

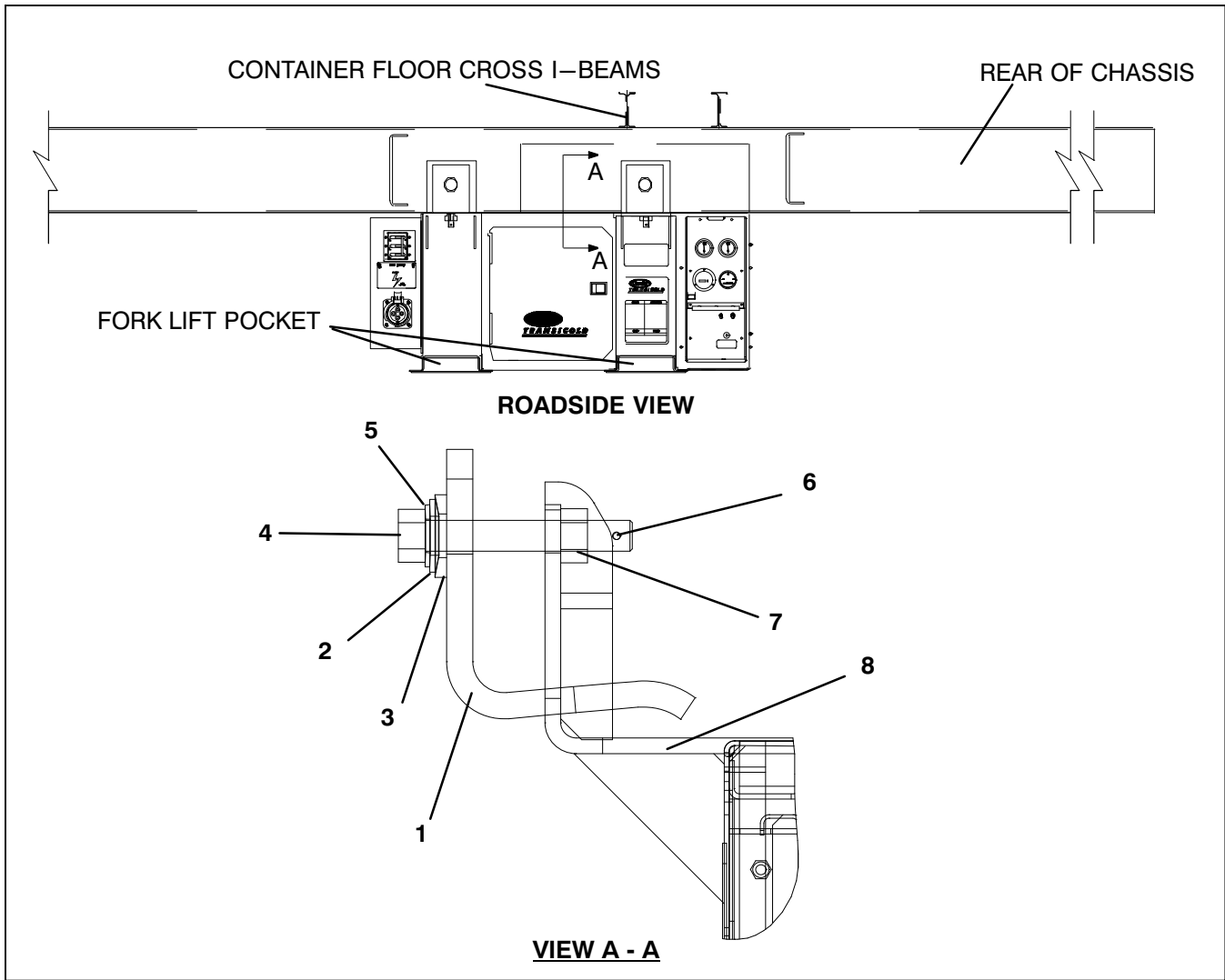

- | | |
|------------------------------|----------------------------------|
| 1. Angle Assembly, Clamp | 5. Washer, Spherical, Belleville |
| 2. Washer, Spherical, Male | 6. Roll Pin |
| 3. Washer, Spherical, Female | 7. Nut, Hex, 3/4-10 |
| 4. Bolt | 8. Frame Assembly |

Figure 2-2 Generator Set Mounting - Quick Mount

2.2 GENERATOR SET REMOVAL

a. Standard Mount

1. Disconnect power cable to generator (if connected).
2. With fork lift in position and safety chain attached, slide mounting plates back sufficiently to clear chassis.
3. Lower and remove generator.

b. Quick Mount

1. Disconnect power cable to unit (if connected).
2. With fork lift in position and safety chain attached, loosen mounting bolts, and lift end of bolts out of slot to orient clamps to open position.

2.3 STARTING AND STOPPING INSTRUCTIONS

2.3.1 Pre-Start Inspection

- a. Check engine lubrication and fuel filters, oil lines, and connections for leaks. If required, tighten connections and/or replace gaskets.
- b. Check engine lubricating oil level. (Refer to paragraph 1.10, table entry f.)
- c. Check poly V-belt for fraying or cracks and proper tension. (Refer to paragraph 4.4.11).
- d. Check radiator hoses for leaks and check radiator coolant level. (Refer to paragraph 1.10, table entry k.)
- e. Check radiator coil and generator air intake screen for cleanliness. If required, clean using compressed air, reversing the normal air flow.
- f. Check air cleaner for cleanliness and clean if necessary. (Refer to paragraph 4.4.12.)
- g. Check in-line fuel strainer and clean if necessary. (Refer to paragraph 4.4.4.)
- h. Drain water from fuel tank sump and filter bowl.
- i. Fill fuel tank with diesel fuel. (Refer to paragraph 1.10, table entry g.)
- j. Check air intake heater amperage. (Refer to paragraph 1.10, table entry i.)
- k. Check battery terminals for cleanliness and secureness. If required, clean, then coat with a battery terminal sealant.
- l. Check, and if required, tighten all electrical connections.
- m. Check, and if required, tighten all hardware (brackets, etc.).
- n. Ensure the main generator set circuit breaker (CB1) is in the OFF position. Connect power cable to refrigeration unit and proceed to paragraph 2.3.2.

2.3.2 Starting Instructions

Before start up, both the Genset circuit breaker (CB1) and the refrigerated unit should be OFF. After start up, the Genset unit should be run for at least two minutes to allow the power source to stabilize before supplying power to the refrigerated unit. This will eliminate the potential of any cold start transient spikes from reaching the refrigerated unit. Cold start transient spikes can potentially cause nuisance over voltage alarms on refrigerated units that are sensitive to electrical spikes or transients.



WARNING

Beware of moving poly V-belt, belt driven components and hot exhaust components.



WARNING

Under no circumstances should ether or any other unauthorized starting aids be used in conjunction with the air intake heater.

NOTE

Piston rings in engines that have operated less than 100 hours may not be fully seated. This may lead to the possibility of oil seepage from the exhaust pipe. To properly seat the rings, operate the engine under full load for a period of 24 hours. If the condition persists, check valve clearance when the engine is cold. (Refer to engine workshop manual listed in paragraph 1.2).

a. Standard Units

1. Make sure that CB-1 is in the OFF position.
2. Hook up the 460 volt cable from the refrigerated unit to the Genset receptacle.
3. Hold intake heater switch (see Figure 1-7) in the PREHEAT position. Suggested hold times for a cold engine are as follows:

COLD ENGINE PREHEAT TIMES	
Ambient Temperature	Time
78° F/ 26° C	5 seconds
32° F to 78° F (0° C to 26° C)	10 seconds
18° F to 32° F (-8° C to 26° C)	20 seconds
Below 18° F/-8° C	30 seconds

4. With the intake heater switch held in the PREHEAT position, place the ignition switch in the START position.
5. After the engine has started, continue to hold the intake heater switch in the PREHEAT position until the engine develops sufficient oil pressure to close the oil pressure safety switch (approximately 5 seconds). When released, the intake heater switch will automatically return to the OFF position and the heater will remain energized for 3 minutes.

b. Units with Auto Start

1. Make sure that CB-1 is in the OFF position.
2. Hook up the 460 volt cable from the refrigerated unit to the Genset receptacle.
3. Place the Ignition switch (IGN) in the RUN position.
4. If the low coolant sensor (LCS) is immersed in coolant, the auto restart module will energize the heater for 30 seconds and the safety buzzer will sound. After the 30 second delay, the unit will attempt to start.

2.3.3 Post-Start Inspection

- a. Allow the Genset unit to run for at least 2 minutes.
- b. Turn on CB-1 for 460 volt units.
- c. Check generator output with a voltmeter. In the no load condition, output should be at 490 (+/- 15 volts) with 1800 engine RPM.
- d. Start refrigeration unit.
- e. Run engine 10 minutes (check total time meter operation).
- f. Listen for abnormal bearing noise (AC generator).
- g. Check fuel lines, lube oil lines, and filters for leaks.
- h. Check exhaust system for leaks.

2.3.4 Stopping Instructions

- a. Place CB-1 in the OFF position.
- b. Place the ignition switch in the OFF position.

2.4 SEQUENCE OF OPERATION



Beware of moving poly V-Belt and belt driven components.

a. Standard Units:

With the intake heater switch (HS) held in the ON position, current flows through the ammeter to the intake heater. While the heater is on, the ammeter will show a 42-amp draw.

A second set of contacts also energizes the safety relay (S).

If the high water temperature switch (HWT) opens to break the safety relay ground connection, the safety relay will not energize, and the engine will not start.

To start the engine, the ignition switch (IGN) is held in the START position. With the switch in the START position, current flows to the start solenoid (SS), through the SS contacts to the starter motor (SM). Current then flows to the intake heater timer, intake heater relay (HR) and to the heater, while simultaneously powering the electronic governor module (EG), fuel solenoid (FS), and engine speed sensor (ESS).

The starter motor turns over the engine resulting in pumping of fuel to the engine cylinders by the injection pump. This fuel is ignited by heat of compression; thus starting the engine. When the engine has developed sufficient oil pressure, the low oil pressure switch (LOP) contacts close to maintain power to the safety relay (S).

Once the engine has started, the intake heater (IH) will remain energized for 3 minutes.

The ignition switch (IGN) will be released. The intake heater switch (HS) will be held for 5 seconds, then released after the ignition switch is released. When the START switch is released, the starter will be disengaged.

With the engine running, the battery charger provides DC power to operate the control system and charge the battery.

b. Units with Auto Start, Low Coolant Sensor:

When the ignition switch (IGN) is placed in the RUN position, 12-volt DC power is applied to the low coolant sensor (LCS), if applicable, and the auto restart module simultaneously. If the coolant level is below the sensor, all the indicator lights on the auto restart module will blink once and the LCS will open the contacts on the low coolant relay, de-energizing the unit's 12-volt DC circuitry. If the coolant level is above the sensor, the auto restart module will maintain power and all lights on the module will illuminate. As the auto restart module performs its self test, the lights will go out individually.

After the self test is complete, the auto restart module will energize the intake heater and sound the audible alarm warning, indicating that the unit has been powered on and will start. The 30-second delay starts at this time. When the 30-second delay expires, power will be applied to the electronic governor and the engine attempts to crank for 15 seconds.

When the engine starts, the intake heater will remain energized for 3 minutes; during this time, the engine/intake heater light and alarm will be energized, the shutdown/lockout time delay of 15 seconds will begin counting, and the starter will be disengaged. During the shutdown/lockout time delay at start up, the auto restart module will disregard the signals to the oil pressure and engine temperature inputs, and the Run sequence will begin. If engine does not start, refer to Table 1.3 for auto restart sequencing.

c. Units with Dual Speed Option:

When the Operating Mode switch is placed in the POWER position, the engine will run continuously at 1800 RPM, 60 Hz (normal operating mode).

When the Operating Mode switch is placed in the ECONOMY position, 12-volts DC will be supplied to the Dual Speed Timer (DT). The timer will pass 12-volts DC to Electronic Governor Module (EG) via pin #15 after a period of two (2) hours. The power to pin #15 will signal the control logic within the EG to throttle the engine to 1500 RPM, 50 Hz operation.

SECTION 3

TROUBLESHOOTING

CONDITION	POSSIBLE CAUSE	REMEDY/ REFERENCE SECTION
3.1 DIESEL ENGINE		
3.1.1 Engine Will Not Start		
Starter motor will not crank or low cranking speed	Battery insufficiently charged Battery terminal post or battery defective Electrical connections at starter are bad Starter motor malfunctions Starter motor solenoid defective Open starting circuit Incorrect grade of lubricating oil	Charge Check Correct See 3.1.4 Engine Manual See 3.1.5 Section 1.10.f.
Starter motor cranks, but fails to start	No fuel in tank Air inside the fuel system Water inside the fuel system Plugged fuel filters Air intake heater is bad Low oil / Oil pressure switch defective Faulty heater switch Plugged fuel lines to injector(s) Mechanical lift fuel pump malfunction Fuses F1, F2, F3, F4 are bad Loose or no connection between wire harness and Electronic Governor Module (EG)	Sections 1.9/1.10.g Section 4.4.1 Drain Sump Replace Section 4.4.15 Section 4.4.8 Section 4.4.16 Engine Manual Engine Manual Check/ replace Check/correct
Starter cranks and engages, but dies after a few seconds	Engine lube oil too heavy Voltage drop in starter cable(s)	Section 1.10.f. Check
3.1.2 Engine Starts Then Stops		
Engine stops after a few rotations	No fuel in tank Intake heater switch not held long enough Fuel filter restricted Air cleaner or hose restricted Engine crankcase breather or hose restricted Safety device open Open wiring circuit to fuel solenoid Fuel solenoid defective Fuel supply restricted Mechanical lift fuel pump malfunction Low oil / Oil pressure switch defective Leak in fuel system Injector nozzle(s) defective Injection pump defective Generator internal overloads open	Sections 1.9/1.10.g. Hold switch Replace Section 4.4.12 Section 4.4.13 Section 1.8 Check Replace Sections 1.10.g., 4.4.2, and 4.4.3 Engine Manual Section 4.4.8 Check Engine Manual Engine Manual Table 1-4

CONDITION	POSSIBLE CAUSE	REMEDY/ REFERENCE SECTION
3.1.3 Engine Will Not Shut Off		
Engine will not shut off	Loose ground connection Improperly seated fuel solenoid	Clean/Tighten Correct
3.1.4 Starter Motor Malfunction		
Starter motor will not crank or turns slowly	Battery insufficiently charged Battery cable connections loose or oxidized Battery cables defective Starter brushes shorted out Starter brushes hang up, defective or have no contact Starter solenoid damaged Ignition switch defective Engine lube oil too heavy	Charge Check/Replace Check/Replace Engine Manual Engine Manual Engine Manual Replace Section 1.10.f.
Starter motor turns, but pinion does not engage	Pinion or ring gear obstructed or worn	Engine Manual
Starter motor does not disengage after switch has been released	Ignition switch is bad Starter motor solenoid is bad	Check/Replace Engine Manual
Pinion does not disengage after engine is running	Starter is bad	Engine Manual
3.1.5 Malfunction In The Engine Starting Circuit		
No power to starter motor solenoid	Battery defective Loose electrical connections	Correct Tighten
Fuel solenoid does not energize or does not remain energized	Battery defective Loose electrical connections Oil pressure switch defective Water temperature safety switch open Fuel solenoid defective Intake heater switch is bad Electronic Governor Module (EG) is bad	Correct Tighten Section 1.8 Section 1.8 Engine Manual Check (Engine Manual) Replace (Section 4.4.15) Check/Replace
Intake heater does not energize	Intake heater switch is bad Timer is bad Heater element is bad Heater relay is bad	Section 4.4.15 Section 4.4.15 Section 4.4.15 Section 4.4.15

CONDITION	POSSIBLE CAUSE	REMEDY/ REFERENCE SECTION
3.2 BATTERY CHARGER (SOLID STATE) (CONTINUED)		
Charger does not charge	<p>Open input circuit breaker Charger is not receiving AC input</p> <p>Charger output is not connected to 12 volt battery</p> <p>Charger is bad</p>	<p>Reset Using a voltmeter, confirm charger is receiving correct (230v) AC voltage. If not, check input connections.</p> <p>Check output wiring connections to battery.</p> <p>Replace</p>
Low output voltage measured across charger output	Battery not connected to charger. It is normal to measure 12 volts or less across charger output with no battery connected	Check charging leads from charger to battery
Reverse polarity connection to battery has caused charger to stop charging	Internal DC fuse blown and possible damage to current carrying components	Replace
3.3 ALTERNATING CURRENT GENERATOR		
No voltage	<p>Loss of residual magnetism in exciter field Circuit breaker tripped Open in stator windings</p> <p>Open or short in rotating rectifiers Short circuited</p> <p>Open in alternator field</p> <p>Shorted exciter armature</p>	<p>Section 4.5.2.a. Check Section 4.5.4/ Replace</p> <p>Section 4.5.1.c. Section 4.5.4/ Replace</p> <p>Section 4.5.4/ Replace</p> <p>Section 4.5.4/ Replace</p>
Low voltage	<p>Low engine speed Excessive load High resistance connections - connections are warm or hot Shorted field</p>	<p>Section 4.4.9 Check Tighten</p> <p>Section 4.5.4/ Replace</p>
Fluctuating voltage (May be indicated by flickering lights)	<p>Fluctuating speed Irregular speed of engine Loose terminal or load connections Bad bearing causing uneven air gap</p>	<p>Section 4.4.9 Engine Manual Tighten Section 4.5.1/ 4.5.3</p>
High voltage	Excessive engine speed	Section 4.4.9

CONDITION	POSSIBLE CAUSE	REMEDY/ REFERENCE SECTION
3.3 ALTERNATING CURRENT GENERATOR (CONTINUED)		
Overheating	Generator overloaded Clogged ventilating screens High temperature surrounding generator Insufficient air circulation Unbalanced load Dry bearing	Check Clean Section 4.4.5 Section 4.5.1 Balance Section 4.5.1/ 4.5.3
Mechanical Noise	Bad bearing Rotor scrubbing on stator Loose laminations Loose or misaligned coupling	Section 4.5.1/ 4.5.3 Section 4.5.1/ 4.5.3 Section 4.5.4/ Replace Section 4.5.4
Generator frame produces shock when touched	Static charge Grounded armature of field coil	Check ground to frame Section 4.5.4/ Replace
3.4 AUTO RE-START OPTION		
When the Ignition switch is placed in the RUN position, nothing happens—no lights illuminate	Wait 30 seconds for intake heater to be activated Coolant level below the low coolant sensor Relay defective Ignition switch defective 3 amp Fuse is bad Loose connector on module Auto restart module is bad Miswired connectors	Wait 1.10.k. Check/Replace Check/Replace Switch Check and Replace Fuse Tighten connector Check for 12 volts at Pin 4/ Replace module Check/Correct wiring
Alarm sounds, but engine does not crank	No voltage at Pin 2 of the connector Check Starter Solenoid Auto restart module is bad	Trace/Correct See 3.1.1 Replace module
Engine starts, but the starter does not disengage	Speed Sensor wiring loose Speed Sensor is bad Auto restart module is bad	Check/Correct Replace Replace module

CONDITION	POSSIBLE CAUSE	REMEDY/ REFERENCE SECTION
3.4 AUTO RE-START OPTION (CONTINUED)		
Engine starts, but shuts down from over speed	Electronic Governor Module (EG) is bad	Replace
Engine cranks, but will not start	Electronic Governor Module (EG) is bad See 3.1.1	Replace See 3.1.1
Engine starts, but shuts down on low oil	See 3.1.2	See 3.1.2
Engine starts, but shuts down on high water temperature	See 3.1.6	See 3.1.6
3.5 DUAL SPEED OPTION		
When the Operating Mode switch is placed in the Economy position, nothing happens.	Wait 2 hours for the Dual Speed Timer (DT) to activate the Electronic Governor Module (EG). The Dual Speed Timer (DT) is bad. 12v is not available to the Dual Speed Timer (DT). 12v is not available to the Operating Mode switch.	Wait Check for 12 volts at Pin 15 Replace module Check/Replace Switch Check/Correct wiring
3.6 ELECTRONIC GOVERNOR MODULE		
Fault	LED flash code	Possible Cause
Engine Over Speed: more than 2,530 RPM	One Long–One Short	ESS or mechanical engine problem
Actuator Wiring Disconnection. No signal from ESS for 2 seconds after RPM is greater than 1,000 RPM for 10 seconds, OR for 5 seconds while engine cranking (no voltage at EG pin 18).	Two Long–One Short	ESS or wiring problem
Speed Sensor Disconnection. Fuel/speed actuator (FS) wiring disconnected or open circuit. Coil Resistance Spec: 2.8 ohm +/- 10%.	Two Long–Three Short	FS or wiring problem
EG supply voltage is greater than 26V.	Two Long–Seven Short	EG or alternator problem

SECTION 4

SERVICE AND PREVENTATIVE MAINTENANCE

4.1 INTRODUCTION

This section covers service for the generator set and general engine service. Refer to the Kubota engine workshop manual, Section 1.1, for additional engine servicing.



WARNING

Beware of moving V-belt and belt driven components.

4.2 PREVENTATIVE MAINTENANCE SCHEDULE

A tabular listing of the recommended preventative maintenance activities and schedule is provided in Table 4-1.

4.3 BATTERY SERVICE

When replacing the battery, determine whether the unit was supplied with a mat in the battery tray. If so equipped, the mat must also be replaced.

4.4 ENGINE SERVICE AND COMPONENTS

4.4.1 Bleeding the Fuel System

The unit is equipped with a mechanical fuel lift pump mounted on the engine next to the injection pump. The fuel system is a closed circuit which will require bleeding if loss of fuel has occurred. To fill and bleed the system, do the following:

- Turn fuel bleed valve (Red, see Figure 1-4) counter-clockwise until fully opened.
- Turn the top of the manual priming pump (see Figure 4-1) counter-clockwise to unlock it, and then hand pump the manual plunger until a positive pressure (resistance) is felt. This will indicate fuel flow.
- Depress and turn the top of the manual priming pump clockwise to lock in place.
- Start engine. (Refer to section 2.3).
- When engine is running properly, turn fuel bleed valve clockwise until fully closed.

4.4.2 Servicing Fuel Pump Internal Filter

The internal fuel filter may become plugged or restricted with foreign particles or wax, which can develop if the wrong grade of fuel is used or untreated fuel is used in cold weather, contaminating the fuel. If the internal filter is plugged, the engine will lose power. Therefore, the filter must be cleaned on a regular basis. The quality of the fuel will affect the filter cleaning schedule (refer to section 4.2).

- Turn nut (item 1) counter-clockwise to loosen and remove.
- Remove banjo fitting (item 2) and let it hang loose, making sure to keep copper rings (item 4) for replacement.

- Turn filter (item 3) counter-clockwise and remove. Check and clean.
- To install, reverse steps 1 through 3.

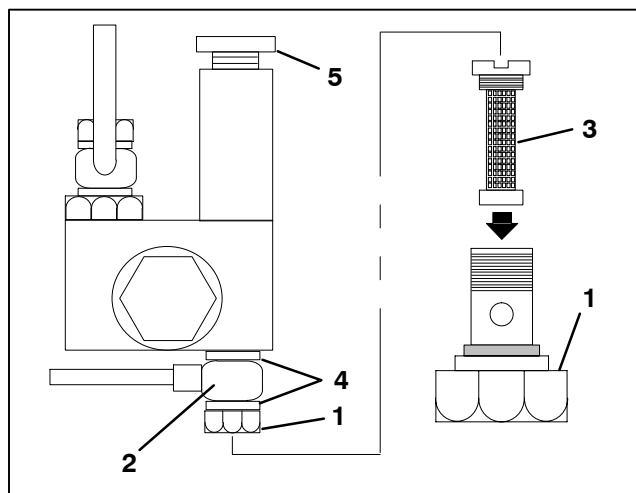

- | | |
|-----------|------------------------|
| 1. Nut | 4. Copper Rings |
| 2. Banjo | 5. Manual Priming Pump |
| 3. Filter | |

Figure 4-1 Mechanical Fuel Pump

4.4.3 Fuel Filter

The full flow filter is located on the generator set frame (see Figure 1-4).

To replace the fuel filter, loosen and remove the filter housing. Lightly oil new gasket with lube oil and replace the filter.

4.4.4 In-Line Fuel Strainer (Option)

Loosen bowl by turning counter-clockwise. To renew, remove in-line fuel strainer, check and clean, and replace.

4.4.5 Cooling System

To ensure adequate cooling, the radiator must be clean, externally and internally. To service the cooling system, do the following:

- Remove all foreign material from the radiator coil by reversing the normal air flow. Compressed air or water may be used as a cleaning agent. It may be necessary to use warm water mixed with any good commercial dishwasher detergent. If a detergent is used, rinse coil(s) with fresh water.
- Drain coolant completely by opening drain cock and removing radiator cap.



CAUTION

Never pour cold water into a hot engine.

- Close drain cock and fill system with clean, untreated water to which between 3% and 5% of an alkaline base radiator cleaner should be added; six ounces (dry) = 151 grams to one gallon (3.8 liter) of water.

- d. Run engine 6 to 12 hours and drain system while warm. Rinse system three times after it has cooled down. Refill system with water.

! CAUTION

Use only ethylene glycol, anti-freeze (with inhibitors) in system. Use of glycol by itself will damage the cooling system (Refer to paragraph 1.10.k.).

- e. Run engine to operating temperature. Drain system again and fill with treated water/anti-freeze (see above Caution note).

4.4.6 Lube Oil Filter

The primary oil filter is located near the radiator fan (see Figure 1-5).

1. After warming up the engine, stop engine, remove drain plug from oil reservoir and drain engine lube oil.
2. Replace filters. Lightly oil gasket on filter before installing.
3. Add lube oil (Refer to paragraph 1.10.f.).
4. Warm up engine and check for leaks.

4.4.7 Servicing the Low Coolant Sensor (Option)

a. Testing the Low Coolant Sensor (LCS)

1. Verify the coolant level is correct.
2. Verify the wiring to the sensor is correct.
3. Check voltage (12.5 to 13.5 VDC) to the B terminal with the ignition switch on (see Figure 4-2).
4. Check continuity between terminals A and C (see Figure 4-2) while 12 VDC is applied to terminal B.
5. Drain the coolant from the system to below the level of the coolant sensor and remove the sensor as described in Section 4.4.7.b., steps 1 and 2 below.
6. With the sensor removed from the radiator and 12 VDC applied to terminal B, the circuit between terminals A and C should be open.

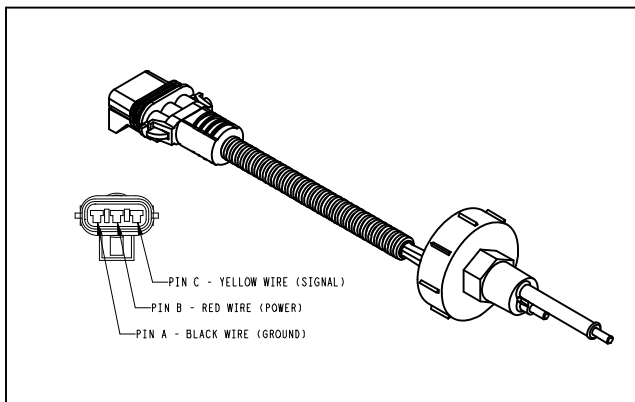

Figure 4-2 Low Coolant Sensor

! CAUTION

Never open the radiator cap when the coolant is hot.

b. Replacing the Low Coolant Sensor (LCS)

1. Loosen the radiator drain pet cock and drain coolant to a point below the sensor into an approved container.
2. Unplug the harness and remove sensor from radiator header.
3. Apply Teflon thread tape or thread sealer to the LCS threads and install sensor.
4. Reconnect the harness and refill the radiator to proper level.

4.4.8 Servicing Low Oil Pressure Switch

- a. Remove harness connection from low oil pressure switch (LOP).
- b. Remove pressure switch from engine.
- c. Apply Teflon thread sealer to threads of new low oil pressure switch.
- d. Install new low oil pressure switch.
- e. Reconnect harness connection to low oil pressure switch.

4.4.9 Engine Speed

The engine speed is electronically controlled. **DO NOT ATTEMPT TO ADJUST ENGINE SPEED.**

4.4.10 Replacing the Engine Speed Sensor

- a. Disconnect the plug to the sensor, (see Figure 1-1).
- b. Remove the bolt securing the sensor to the housing.
- c. Remove the sensor from the housing.
- d. Clean the recess in the housing to ensure that the sensor seats properly when re-installed.
- e. Re-install by sensor, replace the securing bolt and connect the plug to the sensor.

4.4.11 Servicing Poly V-belt

WARNING

Beware of moving poly V-belt and belt driven components.

WARNING

Beware of pinch points.

NOTE

A frayed, cracked or worn poly V-belt must be replaced. After installing a new belt, check the adjustment after running the unit for three or four hours. This will allow for the initial stretch, which is common on new belts. Once this initial stretch has taken place, the belt should be checked at regular intervals.

The poly V-belt is driven by a sheave on the engine crankshaft. Its two functions are: (1) to drive the radiator fan and (2) to drive the water pump.

To replace the poly V-belt, perform the following steps:

- a. Using the proper size socket, slowly rotate the crank on the crank pulley nut. At the same time, use a flat, blunt object to guide the belt off the crank pulley towards radiator. Be careful not to damage grooves on the pulley.
- b. Replace the poly V-Belt by positioning the belt on the water pump pulley, and while rotating the engine (as in step a.), use a flat, blunt object to guide the belt onto the crank pulley. Be careful not to damage grooves on the pulley or belt.

4.4.12 Engine Air Cleaner

The dry element engine air cleaner uses a dry element filter (see Figure 4-3) to filter the engine intake air. The oil bath air cleaner option uses an oil cup instead of the dry element filter (see Figure 4-4).

The engine air cleaner should be inspected regularly for leaks, (see Figure 1-1). A damaged air cleaner or hose can seriously affect the performance and life of the engine. The air cleaner is designed to effectively remove contaminants from the air stream entering the engine. An excessive accumulation of contaminants in the air cleaner will impair its operation. Therefore, a service schedule must be set up and followed.

1. Check all connections for mechanical tightness. Be sure the air cleaner outlet pipe is not fractured.
2. In case of leakage, if adjustment does not correct the problem, replace necessary parts or gaskets. *Swollen or distorted gaskets must always be replaced.*

a. Air Filter Indicator

The air filter indicator, used with the dry element filter, is mounted on the unit frame and connected to the engine air intake. Its function is to indicate when the air cleaner dry element needs to be replaced. In operation: When a plugged air cleaner decreases intake manifold pressure to 500 mm (20") WG, the indicator moves to the red line. The air cleaner element should be replaced and the indicator reset by pressing the reset button.

b. Air Cleaner, Dry Element Service

1. Stop the engine and open the cap clamps (see Figure 4-3) to remove air cleaner bottom cap.
2. Remove the air filter element from the air cleaner body.
3. Install the new element, secure the bottom cap with the cap clamps.

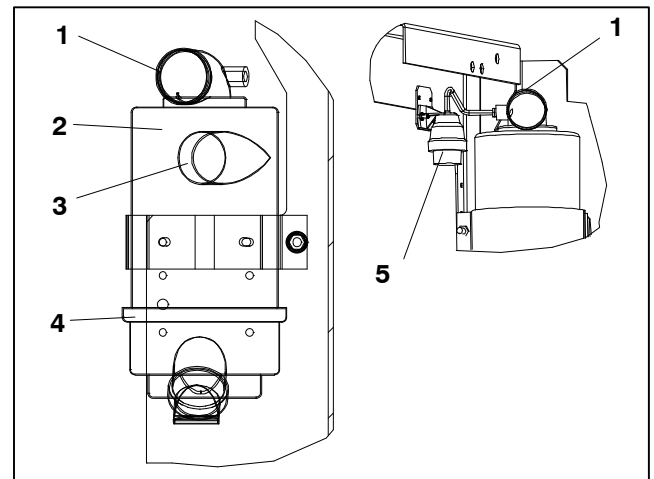

- | | |
|---------------------|-------------------------|
| 1. Air Outlet | 4. Cap Clamp |
| 2. Air Cleaner Body | 5. Air Filter Indicator |
| 3. Air Inlet | |

Figure 4-3 Air Cleaner, Dry Element

c. Air Cleaner, Oil Bath Service

The oil cup should be inspected during pretrip, before each trip. Never allow more than 1/2 inch (12.7 mm) of dirt deposit in the cup. More than 1/2 inch accumulation could result in oil and dirt carrying over into the engine, causing accelerated engine wear. Heavily contaminated oil will not allow the air cleaner to function properly.

CAUTION

Always cover the engine inlet tube while the air cleaner is being serviced.

1. Stop the engine and remove the oil cup from the air cleaner. Dispose of the oil in an environmentally safe manner.
2. Remove the inner oil cup from the oil cup and clean both cups.
3. Reassemble and fill both oil cups to the *indicated level* with oil specified in paragraph 1.10.f.



CAUTION

Do not underfill or overfill the oil bath cups. Overfilling cups causes loss of capacity; underfilling cups causes lack of filtering efficiency.

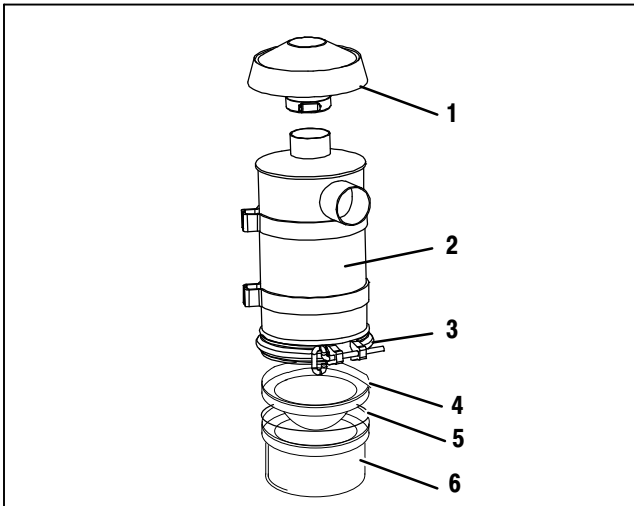

- | | |
|---------------------|------------------|
| 1. Air Inlet Hood | 4. Inner Oil Cup |
| 2. Air Cleaner Body | 5. Gasket |
| 3. Cap Clamp | 6. Oil Cup |

Figure 4-4 Air Cleaner, Oil Bath

d. Air Cleaner Body Service

The air cleaner body should be inspected each time the oil cup is serviced. If there is any sign of contaminant buildup or plugging, the air cleaner body should be removed and back flushed.

At least once a year, or at regular engine service intervals, remove the entire air cleaner and perform the following cleaning procedure:

1. Remove oil cup. Check and clean center tube.



WARNING

Do not use gasoline to clean air cleaner parts.

2. Pump solvent through the air outlet with sufficient force and volume to produce a hard, even stream out of the bottom of the body assembly. Reverse flush until all foreign material is removed.

4.4.13 Engine Crankcase Breather

The engine uses a closed type breather with the breather line attached to the cylinder head cover (see Figure 4-5). It is not necessary to disassemble valve style elements for cleaning. However, the bleed hole should be checked to ensure it is free of obstruction. Check once a year or at every 3,000 hours maintenance interval, whichever comes first.

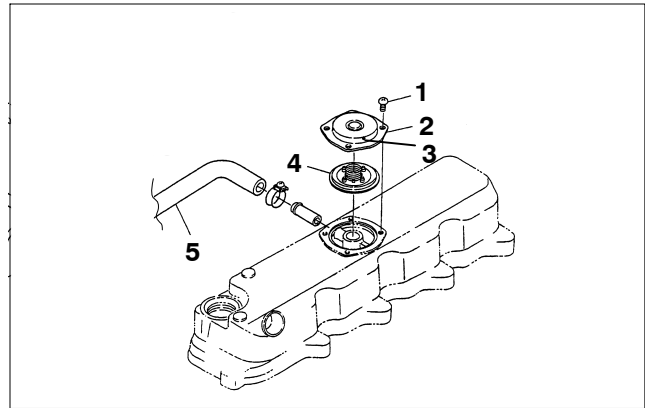

- | | |
|-------------------|-------------------|
| 1. Screw | 4. Breather Valve |
| 2. Breather Cover | 5. Breather Tube |
| 3. Bleed Hole | |

Figure 4-5 Engine Crankcase Breather

4.4.14 Intake Heater Test

- a. Disconnect the lead from the heater terminal (1).
- b. Measure the resistance between the heater positive terminal (1) and the heater body (2).
- c. If the resistance is infinity or significantly different than the specification, *resistance (cold) 0.3 ohms*, replace the heater.

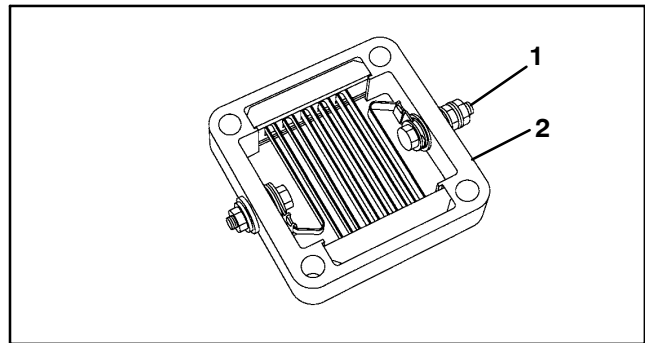

- | | |
|----------------------|----------------|
| 1. Positive Terminal | 2. Heater Body |
|----------------------|----------------|

Figure 4-6 Intake Heater

4.4.15 Intake Heater Service

- a. Remove harness connection from heater.
- b. Remove intake transition mounting hardware.
- c. Remove intake transition, heater and both gaskets.
- d. Clean old gasket material off the transition and manifold mounting services.
- e. Install new heater with a new gasket on either side.
- f. Assemble transition to heater and torque mounting hardware (refer to the engine manual for torque values).
- g. Reconnect harness to heater connection point.
- h. Coat stud on heater with protective coating.

4.4.16 Intake Heater Switch

- a. Remove control box cover.
- b. Remove all connections going to heater switch (HS).
- c. Remove heater switch from control box.
- d. Install new heater switch.
- e. Reconnect wire harness connections to switch.
- f. Confirm that wires are connected to correct terminals.
- g. Reinstall control box cover.

4.5 SERVICING THE ALTERNATING CURRENT GENERATOR

4.5.1 Preventative Maintenance and Operating Precautions

Costly repairs and down time can usually be prevented by operating electrical equipment under conditions that are compatible with those under which the equipment was designed. Follow the instructions outlined below to insure maximum efficiency of the electrical equipment.

a. Cooling

Keep all cooling parts clean. *DO NOT EXCEED TEMPERATURE RISE OF 80C (176F) ABOVE A 40C (104F) AMBIENT.* This ensures that the NEMA Class "F" insulation will not be damaged. *DO NOT EXCEED RATED LOAD* except as specified for the equipment. *OPERATE GENERATOR AT RATED SPEED.* Failure to operate generators at rated load or speed will cause overheating and possible damage to windings due to over voltage or current.

b. Generator Windings (Drying)



Do not direct water or steam into the generator openings. Do not allow any soap and water solutions to enter the alternator.



High voltage (dielectric) testing must not be performed to the machine without first observing NEMA rules. The insulation of this generator winding may be safely checked by using a megger. A high megger reading indicates good insulation.

Generators that have been in transit, recently steam cleaned or in storage for long periods may be subjected to extreme temperature and moisture changes. This can cause excessive condensation, and the generator windings should be thoroughly dried out before bringing the generator up to full nameplate voltage. If this precaution is not taken, serious damage to the generator can result. The following steps should be taken to effectively dry the generator windings:

1. Dry windings by placing generator in drying oven or hot room, or dry with warm air blower directed through windings.

2. If the generator has been operated and is being placed into storage for any period of time, a P.D. George #11127 type air-dry fungus resistant varnish should be applied.

The finest insulation job can be very quickly broken down by carelessly applying high voltage to windings in a moisture saturated condition. Failure to follow these guidelines could easily cause a breakdown, making it necessary to return the generator to the factory for repair.

c. Rotor Damage

If a rotor becomes defective, it should be returned to the factory with full nameplate data. To repair a rotor, the special tooling and technique of the factory are necessary and essential. Should a failure occur, Carrier Transicold should be notified immediately and steps will be taken to return the generator for service.

d. Terminal Strip Cleaning

Open terminal box. Remove dust and debris, and clean terminal strip with wire brush. Reapply protective coating.

4.5.2 Generator Repair/Test Procedures

a. Restoring Residual Magnetism

The direct current (DC) necessary to magnetize the alternator field is obtained from the exciter. Initially, upon starting the generator, current flow and voltage are induced into the exciter armature by the magnetic lines of force set up by the residual magnetism of the exciter field poles.

Residual magnetism of the exciter field poles may be lost or weakened by a strong neutralizing magnetic field from any source, or if the generator is not operated for a long period of time.

Should the generator fail to build up voltage after being disassembled for any reason, a momentary short-circuit of any two generator leads (L1, L2 and L3) while generator is running should be sufficient to correct this condition.



When trying to restore residual magnetism, be sure to wear safety glasses and non-conductive gloves. Use an insulated 12 gauge (or higher) jumper wire. Cut off all but a few strands from both ends of the jumper wire to help prevent fusing.

As an alternate method, apply either an alternating current or a direct current voltage of approximately 20 volts to any two generator leads (L1, L2 and L3) while generator is running. Do not make a positive connection, but rather touch the leads together until the generator voltage begins to rise, then remove. Insert a 30 ampere fuse into the circuit to prevent any damage in case the build-up voltage is not removed quickly enough. Reflash field if generator output voltage does not build up.

b. Winding Insulation Testing

Continuity test results for the stator winding tests are provided in the following table:

Wire Pair	Ohm*	Wire Pair	Ohm*	Wire Pair	Ohm*
T10-T1		T1-T8		T4-T5	
T10-T2		T1-T9		T4-T6	
T10-T3		T2-T3		T4-T7	
T10-T4		T2-T4		T4-T8	
T10-T5		T2-T5	0	T4-T9	
T10-T6		T2-T6		T5-T6	
T10-T7	0	T2-T7		T5-T7	
T10-T8	0	T2-T8		T5-T8	
T10-T9	0	T2-T9		T5-T9	
T1-T2		T3-T4		T6-T7	
T1-T3		T3-T5		T6-T8	
T1-T4	0	T3-T6	0	T6-T9	
T1-T5		T3-T7		T7-T8	0
T1-T6		T3-T8		T7-T9	0
T1-T7		T3-T9		T8-T9	0

* 0 = no resistance (closed circuit) & | = infinite resistance (open circuit)

c. Diode Testing

The rectifier diode assemblies can be tested, and if damaged, replaced. Over current, over voltage, over speed, or reverse currents can damage the assembly or diodes. To remove the diode assemblies and perform diode testing, do the following:

1. Remove the bearing cover by removing the four bolts (see Figure 4-8). Both the bearing and diode assemblies will be visible.
2. Mark and disconnect the alternator rotor wires at the rectifier screw terminals. Note that the terminals are marked with red paint for the forward diode assembly and black for the reverse diode assembly. Mark and disconnect the exciter leads from the double spade terminals (see Figure 4-7).

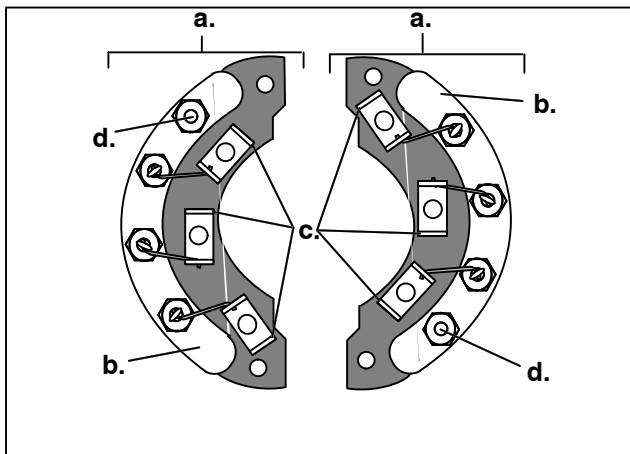

- a. Diode Assembly
- b. Diode Bridge
- c. Exciter Rotor Lead Connection
- d. Alternator Rotor Lead Connection

Figure 4-7 A-C Generator Rectifier Assembly

3. Remove the two cap screws that secure each diode assembly to the exciter. Once this procedure is complete, the diode assemblies are free for removal.
4. A forward diode should have a low resistance when the + of an ohm meter is connected to the exciter rotor lead connection (anode) and the - to the diode bridge (cathode), and a high resistance when the polarity of the ohmmeter is reversed.
5. A reverse diode should have a high resistance when the + of an ohm meter is connected to the exciter rotor lead connection (anode) and the - to the diode bridge (cathode), and a low resistance when the polarity of the ohmmeter is reversed.
6. If both resistances are high or both are low, the diode is defective and the diode assembly should be replaced.

4.5.3 Bearing Replacement

When operated under normal conditions, factory-lubricated shielded bearings will normally provide years of trouble-free service. Excessive bearing load and adverse environment conditions will greatly shorten bearing life. To remove the bearings, do the following:

- a. Remove bearing cover and mylar gasket. (See Figure 4-8).
- b. Remove bearing with a bearing or wheel puller.
- c. Install new bearing. Ball bearings are pre-lubricated and require no additional lubrication for the life of the bearing.
- d. Coat mating surface of bearing cover flange with anti-corrosion compound (Tef-Gel, Carrier Part Number 02-00083-00).
- e. Replace bearing cover and mylar gasket.

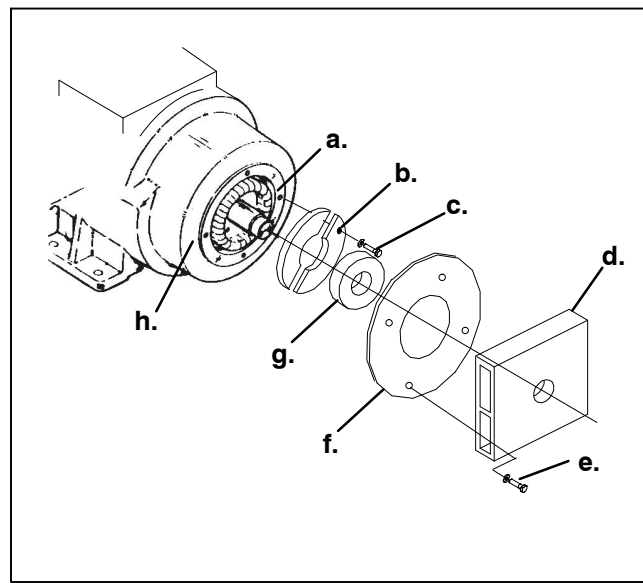

- a. Rectifier Flange
- b. Rectifier Assembly
- c. Rectifier Bolt
- d. Bearing Cover
- e. Bearing Cover Bolt
- f. Mylar Gasket
- g. Bearing
- h. Bearing Cover Flange

Figure 4-8 Rectifier Removal

4.5.4 Generator Removal and Installation

a. Removing the Generator

1. Remove covers and ground wire from frame of generator set.
2. Remove connection box cover and disconnect power leads.
3. Remove screen cover and generator exhaust baffle from coupling end of generator.
4. Remove the six 8mm hex head bolts and washers that secure the generator drive disc to the engine flywheel. Turn bolts counter-clockwise with offset wrench to start, then use flexible shaft and socket assembly for removal of bolts.
5. Remove the twelve 3/8 inch hex head cap screws and washers that secure generator frame to engine flywheel housing.
6. Remove the four 5/8 inch bolts that secure the generator mounting feet to the shockmount bracket, then remove generator.

b. Installing the Generator

NOTE

For torque values refer to paragraph 4.7.

The generator is a single bearing type, which means the shaft end of the rotor floats. Before installing the generator, rotate shaft and check if bearing rotates.

1. Brush anti-seize lubricant (lube-plate) on the face of flywheel.
2. Move generator into position and line up with the holes on housing and flywheel. If required, turn crankshaft to align threaded holes in flywheel with generator drive disc mounting holes.



The rotor should not be pulled out from the alternator more than 0.75 inches. Damage to the bearing and windings may result.

3. Start the 8mm bolts (by hand) through the disc plate and into the flywheel. Once alignment is made torque the six bolts.
4. Secure two of the housing bolts (3/8 inch) on the top and bottom of the generator housing to draw the mating flanges together.
5. Secure the remaining bolts and washers (3/8 inch); torque the 12 bolts in a staggered pattern.
6. Install and torque generator mounting bracket bolts (5/8 inch). Install screen cover, generator exhaust baffle, power leads, ground wiring and generator cover. Install new gasket when installing generator connection box cover.

4.6 GENERAL GENERATOR SET MAINTENANCE

4.6.1 Maintenance Of Painted Surfaces

The unit is protected against the corrosive atmosphere in which it normally operates by a special paint system. However, if the paint system is damaged, the base metal can corrode. If the paint system is scratched or damaged, do the following:

- a. Clean area to bare metal using a wire brush, emery paper or equivalent cleaning method.
- b. Immediately following cleaning, spray or brush on a zinc rich primer.
- c. After the primer has dried, spray or brush on finish coat of paint to match original unit color.

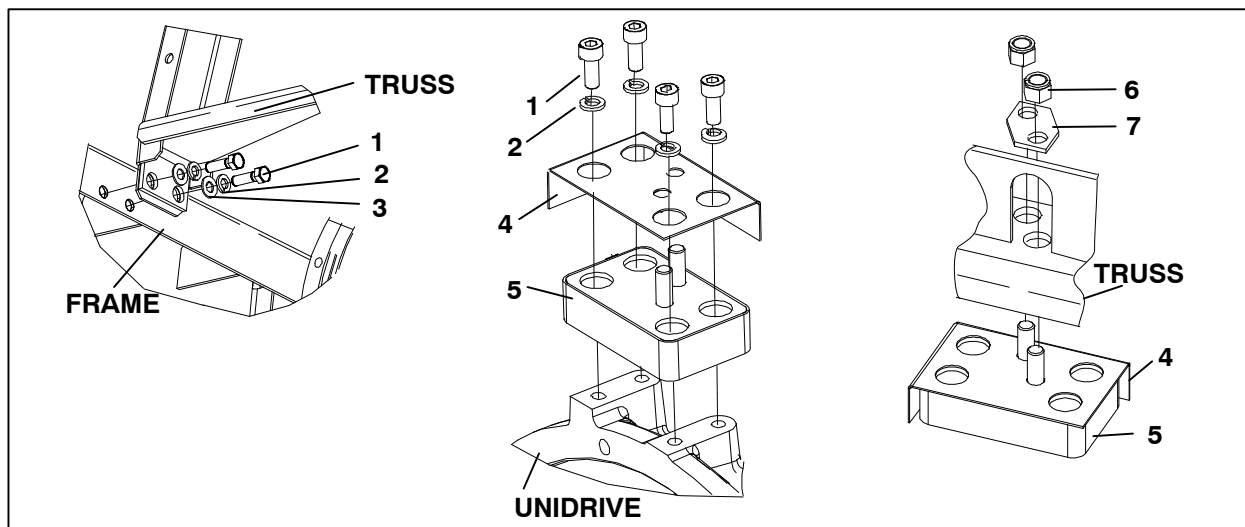

- | | |
|----------------|-------------|
| 1. Bolt | 5. Isolator |
| 2. Lock Washer | 6. Locknut |
| 3. Flat Washer | 7. Nutplate |
| 4. Heat Shield | |

Figure 4-9 Truss and Isolator

4.6.2 Check and Replace Isolators/Shockmounts

a. Replacement Criteria



Continued operation with failed shockmounts may result in engine or generator damage.

When a shockmount has been cut, split, abraded or has flared due to normal deterioration, it must be replaced. Damage to the mounts may not be visible when installed and under load from the component. To correctly inspect shockmounts, they must be removed.

b. Engine Isolator/Shockmount Replacement

1. Use the two lift eyes to lift and support the engine.
2. Remove truss, unidrive isolator and all hardware as shown in Figure 4-9, if equipped.
3. Remove all hardware as shown in Figure 4-10.
4. Raise the engine just enough to remove the shockmounts (Figure 4-10 item 4).
5. Install new shockmounts.

NOTE

For torque values refer to paragraph 4.7.

6. Lower the engine enough to assemble hardware as shown and torque per paragraph 4.7.
7. Remove chains from the lift eyes.

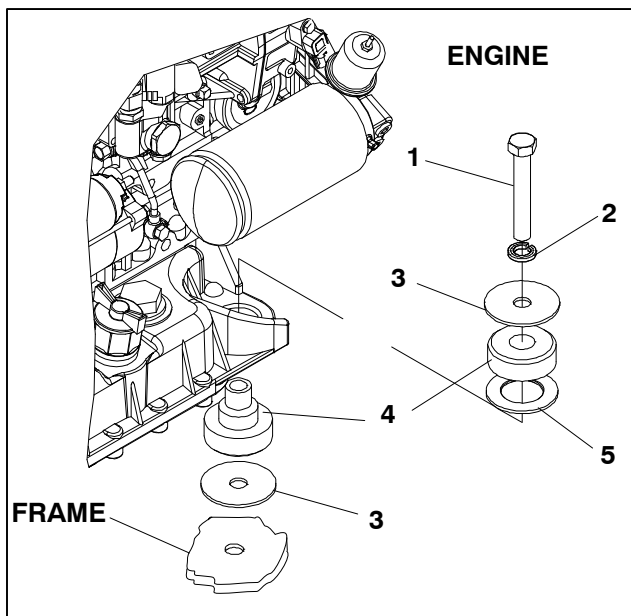

- | | |
|--------------------|----------------|
| 1. Bolt | 4. Shockmount |
| 2. Lock Washer | 5. Flat Washer |
| 3. Snubbing Washer | |

Figure 4-10 Engine Shockmounts

c. Generator Shockmount Replacement

1. Use the two lift eyes to lift and support the engine.
2. Remove shockmount hardware.
3. Raise the generator just enough to remove the shockmounts (Figure 4-11 item 7).
4. Install new shockmounts.
5. Lower the engine enough to assemble hardware as shown and torque. Refer to paragraph 4.7 for torque values.
6. Remove chains from the lift eyes.

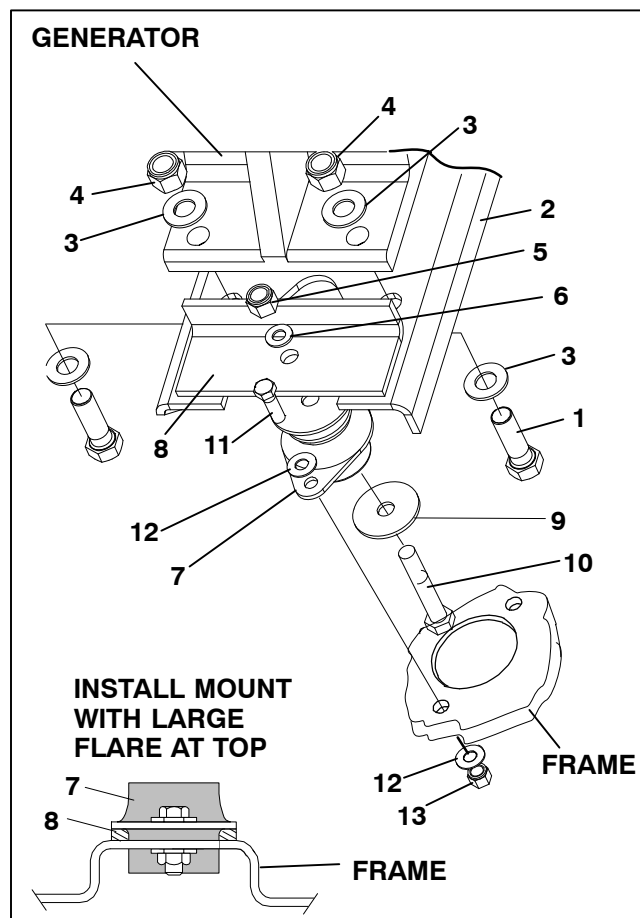

- | | |
|----------------------|-----------------------|
| 1. Screw (5/8) | 8. Support Plate |
| 2. Mounting Base | 9. Snubbing Washer |
| 3. Flat Washer (5/8) | 10. Screw (1/2) |
| 4. Locknut (5/8) | 11. Screw (3/8) |
| 5. Locknut (1/2) | 12. Flat Washer (3/8) |
| 6. Flat Washer (1/2) | 13. Locknut (3/8) |
| 7. Shockmount | |

Figure 4-11 Generator Shockmounts

4.7 UNIDRIVE TORQUE REQUIREMENTS

Extensive damage may occur if the proper hardware is not used and/or proper procedures are not followed when working with the unidrive assembly. Periodic inspection of hardware and bolt torque is recommended to ensure the integrity of the unidrive.

Torque value and hardware requirements for unidrive

assembly are provided in Figure 4-12.

NOTES

SST is an abbreviation for 300 Series Corrosion Resistant Steel.

Loctite #242 or an equivalent product should be used on ALL hardware shown in Figure 4-12.

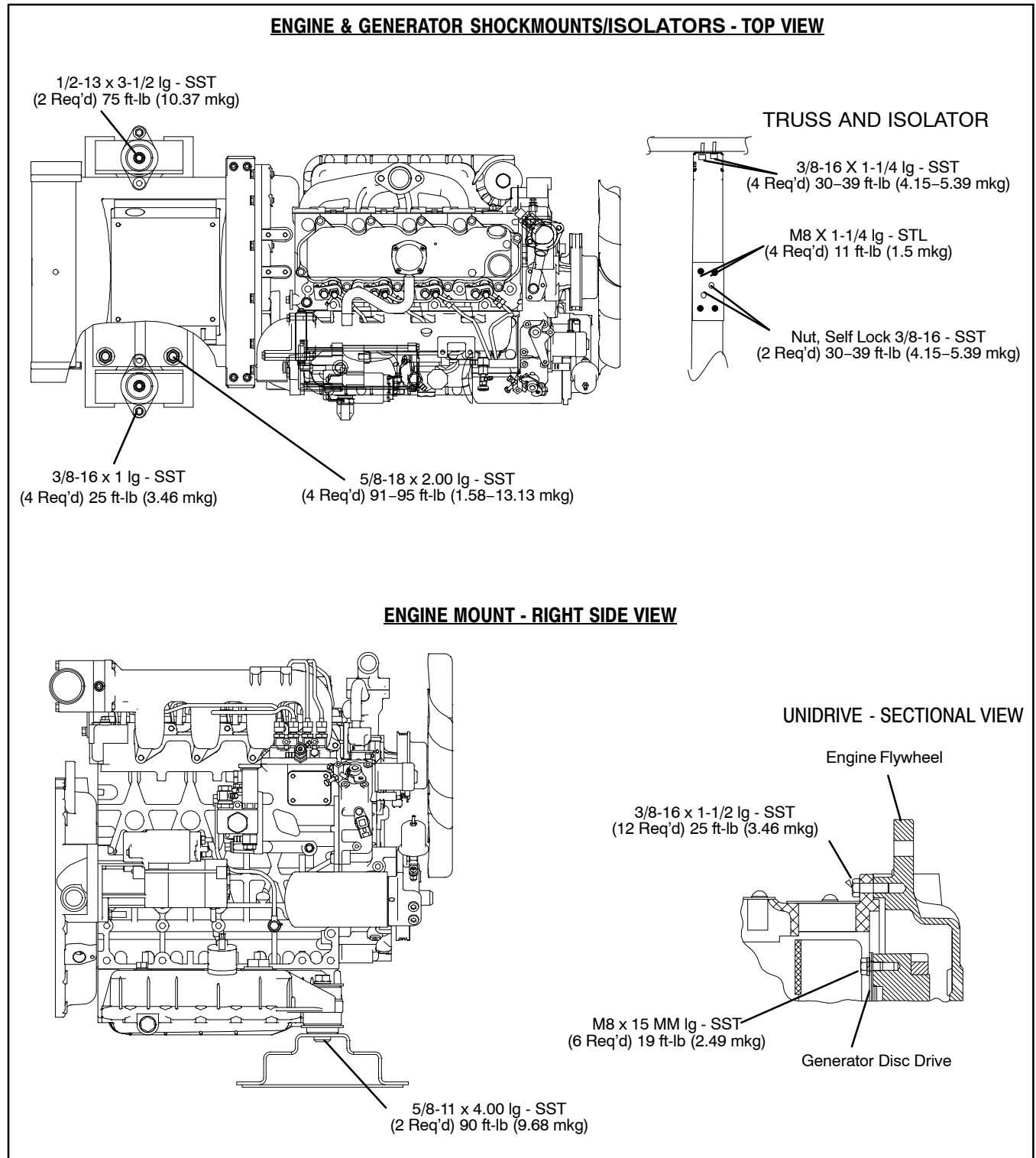

Figure 4-12 Unidrive Torque Requirements

Table 4-1 Preventative Maintenance Actions and Schedule

Description of Procedure	Reference Paragraph	Perform at Pre-Trip Inspection	Standard Service Interval Units		Extended Service Interval Units*
			Every 1000 Hours	Annually or Every 3000 Hours	Annually or Every 3000 Hours
For Pre-Trip inspection, perform items 1 through 15; for "After Start-up" checks, perform items 32 through 36.					
1. Check (In Place) engine/generator shockmounts for cracks, cuts, abrasion or flaring		X			
2. Check engine lubrication, fuel filter, and connections for leaks		X	X		X
3. Check engine lubrication oil level, add as required	1.10.f.	X	X		X
4. Check poly V-Belt for fraying or cracks	4.4.11	X	X		X
5. Check radiator hoses for leaks, check coolant level and 50/50 mixture	1.10.k.	X	X		X
6. Check radiator coil and generator air intake for cleanliness (Clean using compressed air, reversing air flow direction)		X	X		X
7. Check air cleaner					
7a. Oil bath air filter: Check for cleanliness and clean filter body and internal mesh. Change oil every 250 hours	4.4.12.	X	X		X
7b. Dry element air filter with indicator: Check for cleanliness and clean/replace as air filter indicator indicates	4.4.12.	X	X		X
8. Drain water from fuel tank sump and fuel filter bowl		X	X		X
9. Fill fuel tank with diesel fuel; check fuel gauge operation	1.10.g.	X	X		X
10. Check intake heater amperage	1.10.i.	X	X		X
11. Check battery terminals for tightness and cleanliness. Clean and coat terminals with battery terminal sealant		X	X		X
12. Check for dirty/loose electrical connections, frayed cables/wires and cracked insulation		X	X		X
13. Tighten all hardware (brackets, etc.)		X	X		X
14. Clean oil bath air filter body and internal mesh (See Note 2)	4.4.12		X		X
15. Clean mechanical fuel lift pump internal filter	4.4.2	X	X		X
16. Change lubricating oil and filter(s) (See Note 1)	4.4.6		X		X
17. Tighten engine and generator mounting bolts	4.7		X		X
18. Tighten all electrical connections in the control box			X		X
19. Verify operation of engine protective devices			X		X

Table 4-1 Preventative Maintenance Actions and Schedule (Continued)

Description of Procedure	Reference Paragraph	Perform at Pre-Trip Inspection	Standard Service Interval Units		Extended Service Interval Units
			Every 1000 Hours	Annually or Every 3000 Hours	Annually or Every 3000 Hours
20. Check water pump bearing end play	See Engine Manual		X		X
21. Change fuel filter	4.4.3			X	X
22. Clean crankcase breather	4.4.13			X	X
23. Remove and check engine/generator shockmounts for cracks, cuts, splits, abrasion or flaring	4.6.2			X	X
24. Check and, if required, replace poly V-Belt	4.4.11			X	X
25. Clean and flush coolant system	4.4.5			X	See Note 3
26. Check starter condition	See Engine Manual			X	X
27. Check engine compression	See Engine Manual			X	X
28. Check and adjust injector nozzles	See Engine Manual			X	X
29. Perform generator maintenance	4.5.1			X	X
After Starting Generator Set, perform the following:					
30. Check total time meter operation (Allow engine to run for 10 minutes)		X			
31. Listen for abnormal bearing noise		X			
32. Check fuel lines, lube oil lines and filters for leaks		X			
33. Check exhaust system for leaks		X			
34. Check with voltmeter. Generator output should be 490 volts AC +/- 15 volts (engine, 1800 RPM) with a nominal frequency of 60Hz +/- 0.1% Turn refrigeration unit on and check generator 1800 RPM minimum under full load (15 kW)		X			

NOTES:

1. 500 hour interval in extreme operation conditions
2. 250 hour interval in extreme operation conditions
3. Four years or 4000 hours if unit is factory charged with long life (red/orange) coolant

SECTION 5

SCHEMATICS

5.1 INTRODUCTION

This section contains the 12-volt DC control circuit schematics and the 460 volt alternating current generator schematics. To identify the schematics applicable to your PID number refer to Table 1-1.

LINE	SYMBOL	LEGEND
7	●	SPLICE
	— - - —	OPTIONAL
3, 4, 9, 10		ENGINE GROUND
7, 15		CHASSIS GROUND
2	A -	AMMETER
12	BC -	BATTERY CHARGER
2	BAT -	BATTERY
1, 5, 7, 8, 9, 13	CB -	CIRCUIT BREAKER
4, 12	D -	DIODE
6	EG -	ELECTRONIC GOVERNOR MODULE
5	ESS -	ENGINE SPEED SENSOR
6, 7, 8	F -	FUSE
8	FH -	FUEL HEATER
8	FHT -	FUEL HEATER THERMOSTAT
6	FS -	FUEL SOLENOID
2, 3, 9	G -	GENERATOR
2, 11	HR -	INTAKE HEATER RELAY
3	HS -	HEATER SWITCH
4	HWT -	HIGH WATER TEMP. SWITCH
7, 8	IGN -	IGNITION SWITCH
3	IH -	INTAKE HEATER
10	IHT -	INTAKE HEATER TIMER
5	LOP -	LOW OIL PRESS. SWITCH
9	OPG -	OIL PRESSURE GAUGE
9	OPS -	OIL PRESSURE SENDER
5	PE -	PHYSICAL EARTH
2, 3, 9, 11	R1 -	RECEPTACLE
12, 13	R2 -	RECEPTACLE
4, 7	S -	SAFETY RELAY
2	SM -	STARTER MOTOR
2, 9	SS -	STARTER SOLENOID
11	TT -	TIME METER
10	WTG -	WATER TEMP. GAUGE
10	WTS -	WATER TEMP. SENDER

Based On Drawing 62-11411-00 Rev-

Figure 5-1 Schematic Diagram - Legend
(Applies to Figures 5-2 thru 5-3)

460V

G (GENERATOR) CB1 (CIRCUIT BREAKER) R1 (RECEPTACLE)

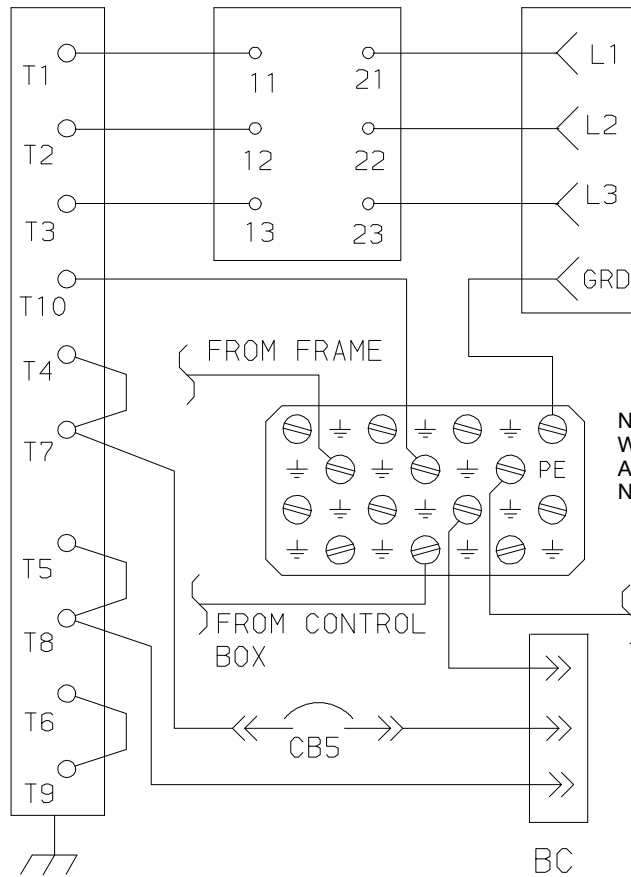

NOTE:
WHEN PE IS NOT FITTED, OUTPUT GROUND WIRES
ARE CONNECTED DIRECTLY AT GENERATOR TERMINAL STRIP TERMINAL T10.

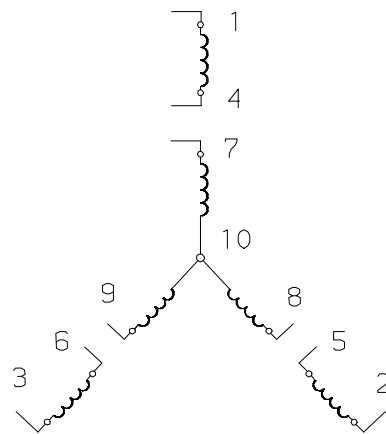

WINDING LAYOUT

Based On Drawing 62-11411-00 Rev-

Figure 5-3 Schematic Diagram 460 Volt Alternating Current Generator
(For Applicability, Refer to Table 1-1)

LINE	SYMBOL	LEGEND
4	●	SPLICE
	— - - —	OPTIONAL
2, 8, 11, 12, 17	⊥	ENGINE GROUND
23	⏏	CHASSIS GROUND
1	A -	AMMETER
16, 21	BC -	BATTERY CHARGER
1	BAT -	BATTERY
2, 7, 16, 18, 21	CB -	CIRCUIT BREAKER
7	CM -	CONTROL MODULE
13	D -	DIODE
4	EG -	ELECT. GOVERNOR MODULE
10	ESA -	ENGINE START ALARM
9	ESL -	ENGINE START LIGHT
3	ESS -	ENGINE SPEED SENSOR
4, 6, 7	F -	FUSE
10	FH -	FUEL HEATER
3	FS -	FUEL SOLENOID
18	G -	GENERATOR
2, 8	HR -	INTAKE HEATER RELAY
8	HWT -	HIGH WATER TEMP. SWITCH
5	IGN -	IGNITION SWITCH
2	IH -	INTAKE HEATER
14	LCS -	LOW COOLANT SENSOR
7	LOP -	LOW OIL PRESS. SWITCH
7, 14	LR -	LOW COOLANT RELAY
11	OPG -	OIL PRESSURE GAUGE
11	OPS -	OIL PRESSURE SENDER
18	R1 -	RECEPTACLE
5, 10	S -	SAFETY RELAY
2	SM -	STARTER MOTOR
6, 11	SR -	STARTER RELAY
2, 11	SS -	STARTER SOLENOID
13	TT -	TIME METER
12	WTG -	WATER TEMP. GAUGE
12	WTS -	WATER TEMP. SENDER

Based On Drawing 62-11413-00 Rev A

Figure 5-4 Schematic Diagram - Legend

(Applies to Figures 5-5 thru 5-6)

460V

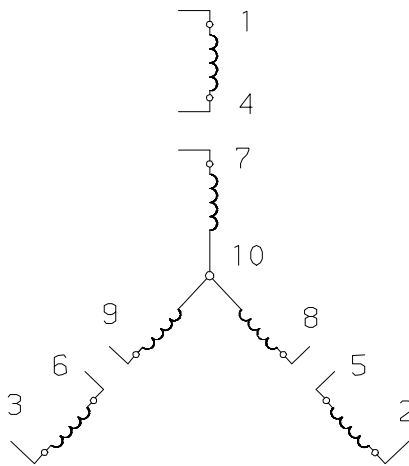
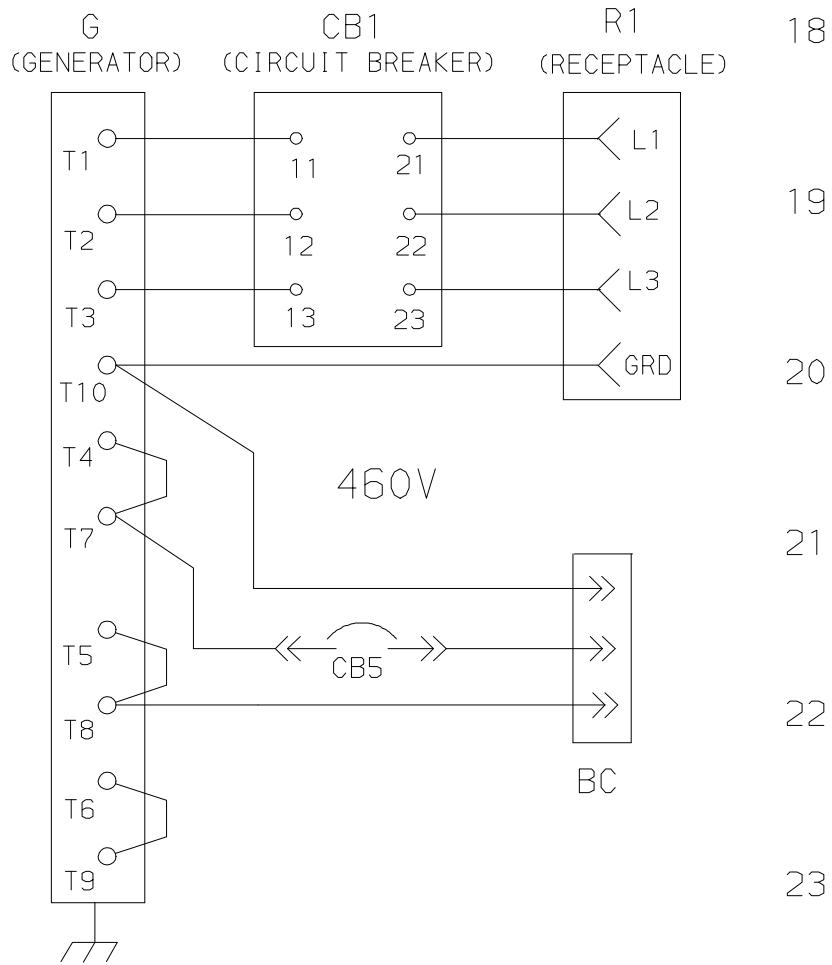

WINDING LAYOUT

Based On Drawing 62-11413-00 Rev A

Figure 5-6 Schematic Diagram 460 Volt Alternating Current Generator
(For Applicability, Refer to Table 1-1)

LINE	SYMBOL	LEGEND
4	⊙	SPLICE
	— — — —	OPTIONAL
2, 8, 11, 12, 17		ENGINE GROUND
23		CHASSIS GROUND
1	A -	AMMETER
16, 21	BC -	BATTERY CHARGER
1	BAT -	BATTERY
2, 7, 16, 18, 21	CB -	CIRCUIT BREAKER
7	CM -	CONTROL MODULE
13	D -	DIODE
10	DS -	DUAL SPEED SWITCH (OPTION)
10	DT -	DUAL SPEED TIMER (OPTION)
4	EG -	ELECT. GOVERNOR MODULE
10	ESA -	ENGINE START ALARM
9	ESL -	ENGINE START LIGHT
3	ESS -	ENGINE SPEED SENSOR
4, 5, 6, 7	F -	FUSE
3	FS -	FUEL SOLENOID
18	G -	GENERATOR
2, 8	HR -	INTAKE HEATER RELAY
8	HWT -	HIGH WATER TEMP. SWITCH
5	IGN -	IGNITION SWITCH
2	IH -	INTAKE HEATER
14	LCS -	LOW COOLANT SENSOR
7	LOP -	LOW OIL PRESS. SWITCH
7, 14	LR -	LOW COOLANT RELAY
11	OPG -	OIL PRESSURE GAUGE
11	OPS -	OIL PRESSURE SENDER
18	R1 -	RECEPTACLE
5, 11	S -	SAFETY RELAY
2	SM -	STARTER MOTOR
6, 12	SR -	STARTER RELAY
2, 12	SS -	STARTER SOLENOID
13	TT -	TIME METER
12	WTG -	WATER TEMP. GAUGE
12	WTS -	WATER TEMP. SENDER

Based On Drawing 62-11466-00 Rev B

Figure 5-7 Schematic Diagram - Legend
(Applies to Figures 5-8 thru 5-9)

460V

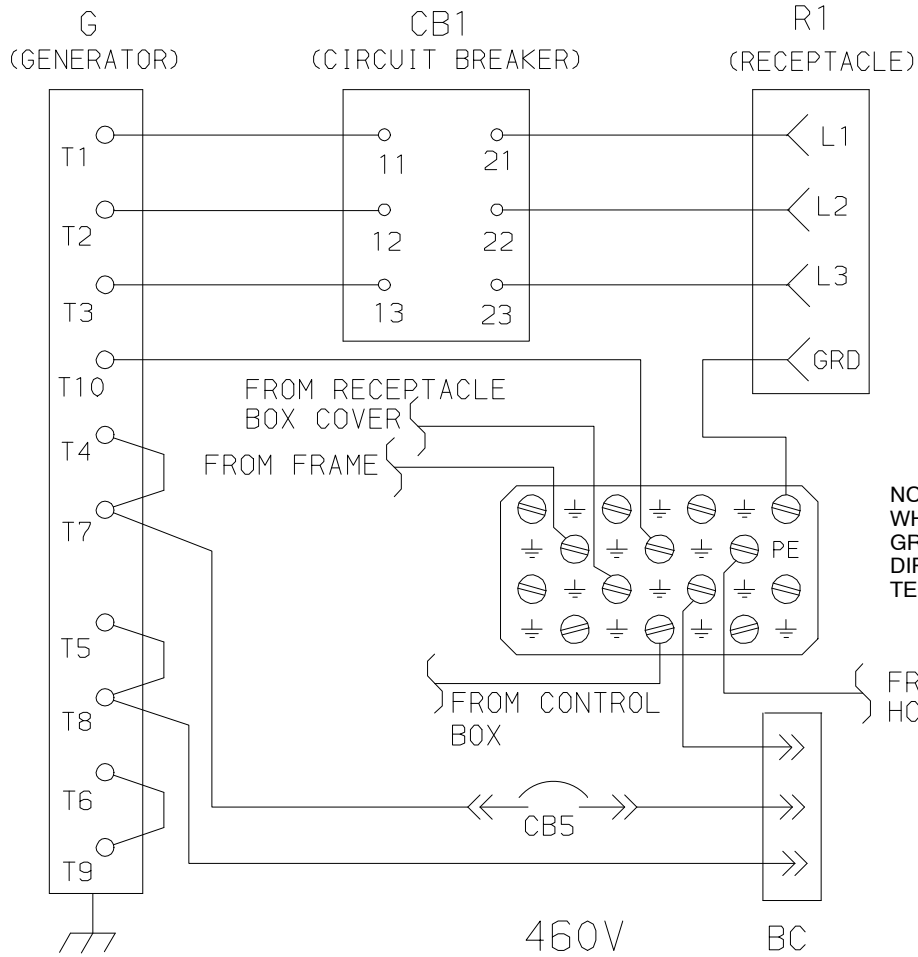

NOTE:
 WHEN PE IS NOT FITTED, OUTPUT GROUND WIRES ARE CONNECTED DIRECTLY AT GENERATOR TERMINAL STRIP TERMINAL T10.

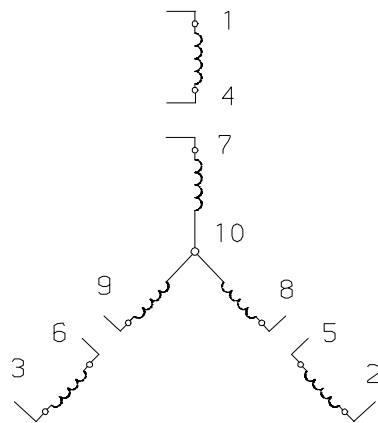

WINDING LAYOUT

Based On Drawings 62-11466-00 Rev- B

Figure 5-9 Schematic Diagram 460 Volt Alternating Current Generator
 (For Applicability, Refer to Table 1-1)

LINE	SYMBOL	LEGEND
7	⊙	SPLICE
	— - - —	OPTIONAL
3,4,9,10		ENGINE GROUND
7,15		CHASSIS GROUND
2	A —	AMMETER
12	BC —	BATTERY CHARGER
2	BAT —	BATTERY
1,5,7,8,9,13	CB —	CIRCUIT BREAKER
4,12	D —	DIODE
11	DS —	DUAL SPEED SWITCH (OPTION)
11	DT —	DUAL SPEED TIMER (OPTION)
6	EG —	ELECTRONIC GOVERNOR MODULE
5	ESS —	ENGINE SPEED SENSOR
6,7,8,9	F —	FUSE
6	FS —	FUEL SOLENOID
8	FHT —	FUEL HEATER, INTEGRATED
—	FW —	FUEL WARMER
2,3,9	G —	GENERATOR
2,10	HR —	INTAKE HEATER RELAY
3,4	HS —	HEATER SWITCH
4	HWT —	HIGH WATER TEMP. SWITCH
7,8	IGN —	IGNITION SWITCH
3	IH —	INTAKE HEATER
10	IHT —	INTAKE HEATER TIMER
5	LOP —	LOW OIL PRESS. SWITCH
9	OPG —	OIL PRESSURE GAUGE
9	OPS —	OIL PRESSURE SENDER
5	PE —	PHYSICAL EARTH
2,3,9,11	R1 —	RECEPTACLE
12,13	R2 —	RECEPTACLE
4,7	S —	SAFETY RELAY
2	SM —	STARTER MOTOR
2,9	SS —	STARTER SOLENOID
11	TT —	TIME METER
10	WTG —	WATER TEMP. GAUGE
10	WTS —	WATER TEMP. SENDER

FUEL HEATER IS STANDARD W/SINGLE SPEED
 FUEL WARMER IS STANDARD W/DUAL SPEED

Based On Drawing 62-11438-00 Rev D

Figure 5-10 Schematic Diagram - Legend
 (Applies to Figures 5-11 thru 5-12)

460V

G (GENERATOR) CB1 (CIRCUIT BREAKER) R1 (RECEPTACLE)

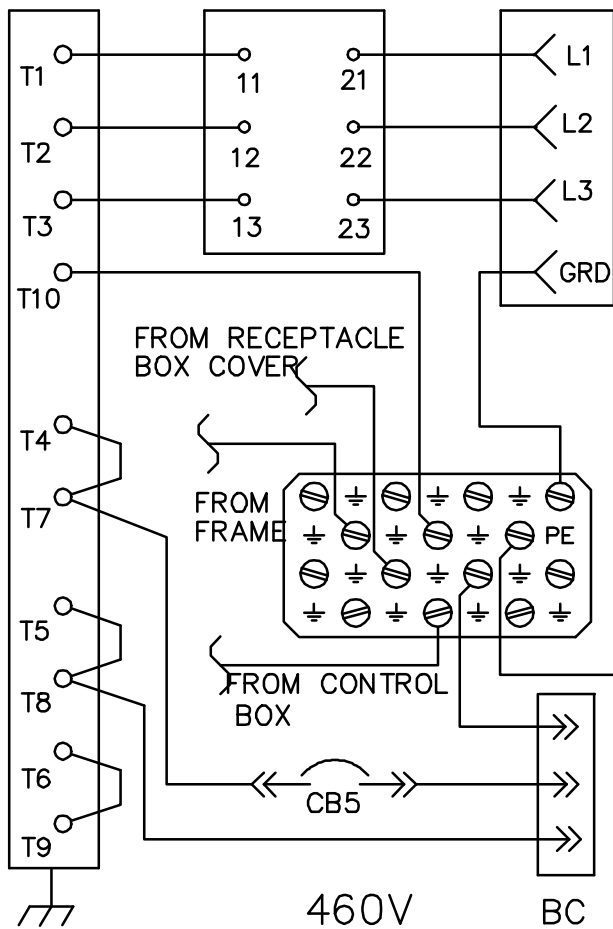

NOTE:
WHEN PE IS NOT FITTED, OUTPUT
GROUND WIRES ARE CONNECTED
DIRECTLY AT GENERATOR
TERMINAL STRIP TERMINAL T10.

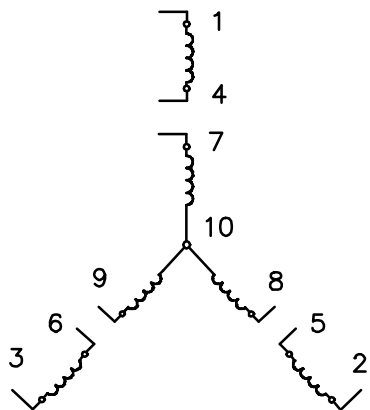

WINDING LAYOUT

Based On Drawing 62-11438 Rev D

Figure 5-12 Schematic Diagram 460 Volt Alternating Current Generator

(For Applicability, Refer to Table 1-1)

LINE	SYMBOL	LEGEND
7	⊙	SPLICE
	— - - —	OPTIONAL
3,4,9,10		ENGINE GROUND
7,15		CHASSIS GROUND
2	A —	AMMETER
12	BC —	BATTERY CHARGER
2	BAT —	BATTERY
1,5,7,8,9,13	CB —	CIRCUIT BREAKER
4,12	D —	DIODE
11	DS —	DUAL SPEED SWITCH (OPTION)
11	DT —	DUAL SPEED TIMER (OPTION)
6	EG —	ELECTRONIC GOVERNOR MODULE
5	ESS —	ENGINE SPEED SENSOR
6,7,8	F —	FUSE
8	FHT —	FUEL HEATER
6	FS —	FUEL SOLENOID
—	FW —	FUEL WARMER
2,3,9	G —	GENERATOR
2,11	HR —	INTAKE HEATER RELAY
3,4	HS —	HEATER SWITCH
4	HWT —	HIGH WATER TEMP. SWITCH
7,8	IGN —	IGNITION SWITCH
3	IH —	INTAKE HEATER
10	IHT —	INTAKE HEATER TIMER
5	LOP —	LOW OIL PRESS. SWITCH
9	OPG —	OIL PRESSURE GAUGE
9	OPS —	OIL PRESSURE SENDER
5	PE —	PHYSICAL EARTH
2,3,9,11	R1 —	RECEPTACLE
12,13	R2 —	RECEPTACLE
4,7	S —	SAFETY RELAY
2	SM —	STARTER MOTOR
2,9	SS —	STARTER SOLENOID
11	TT —	TIME METER
10	WTG —	WATER TEMP. GAUGE
10	WTS —	WATER TEMP. SENDER

FUEL HEATER IS STANDARD W/SINGLE SPEED
 FUEL WARMER IS STANDARD W/DUAL SPEED

Based On Drawing 62-11441-00 Rev D

Figure 5-13 Schematic Diagram - Legend
 (Applies to Figures 5-14 thru 5-15)

460V

G (GENERATOR) CB1 (CIRCUIT BREAKER) R1 (RECEPTACLE)

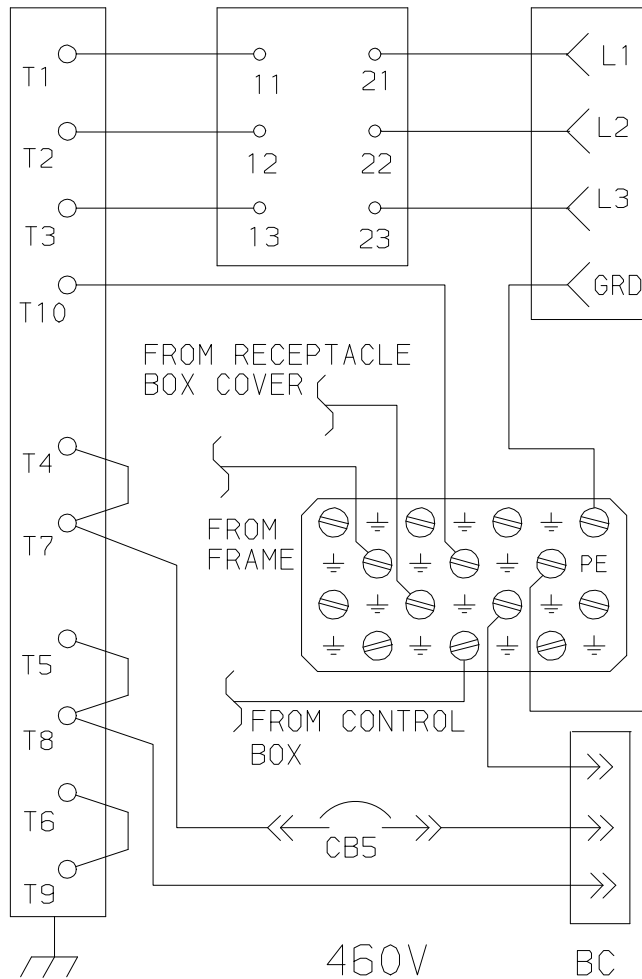

NOTE:
WHEN PE IS NOT FITTED, OUTPUT
GROUND WIRES ARE CONNECTED
DIRECTLY AT GENERATOR
TERMINAL STRIP TERMINAL T10.

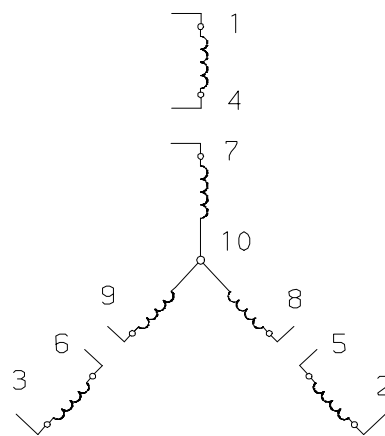

WINDING LAYOUT

Based On Drawing 62-11441 Rev D

Figure 5-15 Schematic Diagram 460 Volt Alternating Current Generator

(For Applicability, Refer to Table 1-1)

INDEX

A

AC Generator Description, 1–6
Air Cleaner, Dry Element Service, 4–3
Air Cleaner, Oil Bath Service, 4–3
Air Filter Indicator, 4–3
Alternating Current Generator Diagram, 1–6
Ammeter, 1–7
Auto Restart Module, 1–7
Auto Restart Preset Values, 1–9
Auto Restart Sequencing, 1–10

B

BATTERY CHARGING SYSTEM, 1–6
Battery Service, 4–1
Bearing Replacement, 4–6
Bleeding the Fuel System, 4–1

C

Control Panel, 1–7
Cooling System, 4–1

D

Diode Testing, 4–6
Dual Speed Timer, 1–7

E

Electronic Governor Module, 1–5
Engine Air Cleaner, 4–3
Engine Air System, 1–5
Engine Crankcase Breather, 4–4
Engine Data, 1–13
Engine Description, 1–5
Engine Isolator/Shockmount Replacement, 4–8
Engine Screw Threads, 1–6
Engine Service, 4–1
Engine Speed, 4–2
Engine Speed Sensor Replacement, 4–2

F

First Aid, Safety–i
Fuel Filter, 4–1
Fuel Pump Filter Service, 4–1
Fuel System, 1–5

G

Gauges and Senders, 1–7
Generator Principle of Operation, 1–6
Generator Removal and Installation , 4–7
Generator Repair, 4–5
Generator Service, 4–5
Generator Set Installation, 2–1
Generator Set Removal, 2–2
Generator Test Procedures, 4–5
Generator Windings, 4–5

H

Hazard Label Identification, Safety–i

I

Ignition Switch, 1–7
In–Line Fuel Strainer, 4–1
Insulation Testing, 4–6
Intake Heater Service, 4–4
Intake Heater Switch, 1–7, 4–5
Intake Heater Test, 4–4
Intake Heater Timer, 1–7

L

Low Coolant Sensor, 1–7
Low Coolant Sensor Service, 4–2
Low Oil Pressure Switch Service, 4–2
Lube Oil Filter, 1–5, 4–2

INDEX (Continued)

M

Maintenance Precautions, Safety-i
Manual Switches, 1-7
Meters, 1-7
Model Chart, 1-2

O

Operating Controls and Instruments, 1-7
Operating Precautions, Safety-i

P

Poly V-Belt Service, 4-3
Post-Start Inspection, 2-3
Pre-Start Inspection, 2-3
Preventative Maintenance and Operating Precautions
 , 4-5
Preventative Maintenance Schedule, 4-1, 4-10

S

Safety Devices, 1-12
Safety Notices, Safety-i
Safety Summary, Safety-i
Schematics, 5-1
SEQUENCE OF OPERATION, 2-4
Starting Instructions, 2-3
Stopping Instructions, 2-3

T

Timers, 1-7
Torque Requirements, 4-9
Total Time Meter, 1-7
Troubleshooting, 3-1

U

Unit Introduction, 1-1
Unit Specifications, 1-13



A member of the United Technologies Corporation family. Stock symbol UTX
©2010 Carrier Corporation • Printed in U. S. A. 11/11



Carrier

A United Technologies Company

Carrier Transicold Division,
Carrier Corporation
Container Products Group
P.O. Box 4805
Syracuse, N.Y. 13221 U.S.A

www.carrier.transicold.com